

AMERICAN RIVER FLOOD CONTROL DISTRICT

RESOLUTION NO. 2022-11

PROCLAIMING A LOCAL EMERGENCY PERSISTS, RE-RATIFYING THE COVID-19 STATE OF EMERGENCY, AND RE-AUTHORIZING REMOTE TELECONFERENCE MEETINGS OF AMERICAN RIVER FLOOD CONTROL DISTRICT PURSUANT TO THE RALPH M. BROWN ACT.

WHEREAS, the AMERICAN RIVER FLOOD CONTROL DISTRICT is committed to preserving and nurturing public access and participation in meetings of the Board of Trustees; and

WHEREAS, all meetings of the AMERICAN RIVER FLOOD CONTROL DISTRICT are open and public, as required by the Ralph M. Brown Act (Gov. Code, §§ 54950 – 54963) (“Brown Act”), so that any member of the public may attend, participate, and watch the District’s legislative body conduct its business; and

WHEREAS, Assembly Bill 361 added Government Code section 54953(e) to make provisions for remote teleconferencing participation in meetings by members of a legislative body, without compliance with the requirements of Government Code section 54953(b)(3), subject to the existence of certain conditions; and

WHEREAS, a required condition is that a state of emergency is declared by the Governor pursuant to Government Code section 8625, proclaiming the existence of conditions of disaster or of extreme peril to the safety of persons and property within the state caused by conditions as described in Government Code section 8558; and

WHEREAS, a proclamation is made when there is an actual incident, threat of disaster, or extreme peril to the safety of persons and property within the jurisdictions that are within the District’s boundaries, caused by natural, technological, or human-caused disasters; and

WHEREAS, it is further required that state or local officials have imposed or recommended measures to promote social distancing, or, the legislative body meeting in person would present imminent risks to the health and safety of attendees; and

WHEREAS, the Board of Trustees previously adopted a Resolution, number 2021-06 on October 8, 2021, finding that the requisite conditions exist for the District to conduct remote teleconference meetings without compliance with paragraph (3) of subdivision (b) of section 54953; and

WHEREAS, as a condition of extending the use of the provisions found in Section 54953(e), the Board of Trustees must reconsider the circumstances of the state of emergency that exists in the District, and the Board of Trustees has done so; and

WHEREAS, such conditions persist in the District, specifically, the March 4, 2020 State of Emergency Proclamation remains active in California due to the threat of COVID-19; and

WHEREAS, the Board of Trustees does hereby find that the ongoing risk posed by the highly transmissible COVID-19 virus has caused, and will continue to cause, conditions of peril to the safety of persons within the District that are likely to be beyond the control of services, personnel, equipment, and facilities of the District; and

WHEREAS, as a consequence of the local emergency persisting, the Board of Trustees does hereby find that the District shall continue to conduct its meetings without compliance with paragraph (3) of subdivision (b) of Government Code section 54953, as authorized by subdivision (e) of section 54953, and that the Board shall comply with the requirements to provide the public with access to the meetings as prescribed in paragraph (2) of subdivision (e) of section 54953; and

WHEREAS, all meeting agendas, meeting dates, times, and manner in which the public may participate in the public meetings of the District and offer public comment by telephone or internet-based service options including video conference will continue to be posted on the District website and physically outside of the District office.

NOW, THEREFORE, THE BOARD OF TRUSTEES OF AMERICAN RIVER FLOOD CONTROL DISTRICT DOES HEREBY RESOLVE AS FOLLOWS:

Section 1. Recitals. The Recitals set forth above are true and correct and are incorporated into this Resolution by this reference.

Section 2. Affirmation that Local Emergency Exists. The Board has reconsidered the conditions of the state of emergency and proclaims that a local emergency persists throughout the District because the high risk of transmissibility of COVID-19 continues to pose an imminent risk to the safety of persons in the District.

Section 3. Re-ratification of Governor's Proclamation of a State of Emergency. The Board hereby ratifies the Governor of the State of California's Proclamation of State of Emergency, effective as of its issuance date of March 4, 2020.

Section 4. Remote Teleconference Meetings. District staff are hereby authorized and directed to take all actions necessary to carry out the intent and purpose of this Resolution including, conducting open and public meetings in accordance with Government Code section 54953(e) and other applicable provisions of the Brown Act.

Section 5. Effective Date of Resolution. This Resolution shall take effect immediately upon its adoption and shall be effective until the earlier of (i) July 8, 2022, or such time the Board of Trustees adopts a subsequent resolution in accordance with Government Code section 54953(e)(3) to extend the time during which the District may continue to teleconference without compliance with paragraph (3) of subdivision (b) of section 54953.

PASSED AND ADOPTED by the Board of Trustees of AMERICAN RIVER FLOOD CONTROL DISTRICT, this _____ day of _____, 2022, by the following vote:

AYES:

NOES:

ABSENT:

ABSTAIN:

May 13, 2022
Sacramento, California

In Compliance with CA Assembly Bill 361 the Board of Trustees of the American River Flood Control District met in regular session at 11:00 a.m. on Friday, May 13, 2022 by teleconference. In attendance were Trustee Shah, Trustee Johns, Trustee Holloway, Trustee L'Ecluse and Trustee Vander Werf. Trustee Shah presided. Also present from the District were General Manager (GM) Tim Kerr, Field Supervisor Scott Webb, Legal Counsel Rebecca Smith and Office Manager Malane Chapman. Two members of the public were present.

Item No. 1 Resolution No. 2022-09; Proclaiming a Local Emergency Persists, Re-Ratifying the COVID-19 State of Emergency, and Re-Authorizing Remote Teleconference Meeting of American River Flood Control District Pursuant to the Ralph M. Brown Act: On a motion by Trustee Holloway seconded by Trustee Shah, the Board unanimously approved this item.

Roll Call Vote:

Trustee Holloway:	AYE	Trustee Johns:	AYE
Trustee L'Ecluse:	AYE	Trustee Shah:	AYE
Trustee Vander Werf:	AYE		

Item No. 2 Public Comments on Non-Agenda Items:

Item No. 3 Approval of Consent Agenda: On a motion by Trustee Holloway seconded by Trustee Shah, the Board unanimously approved items 3a) Minutes of Regular Meeting on April 8, 2022, 3b) Approval of Report of Investment Transactions March 2022 (City Pool, LAIF, River City) and Treasurer's Certification, 3c) District Financial Reports: Statement of Operations (April 2022) and Cash Flow Report, 3d) Finance Committee Recommendations: Annual Review of Credit Card Policy, Reserve Fund Policy, and Investment Policy, and 3e) Correspondence: None.

Items No. 4 Accounts Payable and General Fund Expenses (April 2022): Trustee Vander Werf inquired about the payment Kent Arborist Services. Trustee Holloway inquired about payment to Hunt & Sons. On a motion by Trustee Holloway seconded by Trustee L'Ecluse, the Board unanimously approved payments on the Schedule of Accounts Payable (April 2022) of \$86,753.54 and General Fund Expenses of \$112,945.03 (total aggregate sum \$199,698.57).

Roll Call Vote:

Trustee Holloway:	AYE	Trustee Johns:	AYE
Trustee L'Ecluse:	AYE	Trustee Shah:	AYE
Trustee Vander Werf:	AYE		

At 11:08 a.m. the Trustees met in closed session with District Counsel Smith and GM Kerr.

Item No. 5 Conference with Legal Counsel – Anticipated Litigation: Government Code 54956.9(b) – One Case

The Trustees returned to open session at 11:55 a.m. and Legal Counsel reported that District will begin the process of working with a contractor who will respectfully, carefully and humbly start clearing the parcel.

Item No. 6 Lathrop Way Encampments No action was taken on this item by the Board

Item No. 7 Finance Committee Recommendations:

a) District Budget Fiscal Year 2022-2023

b) District 5-year Budget Projections

Trustee Vander Werf reported that the Finance Committee met and reviewed the proposed budget and 5-year projections with staff and recommends that the Board approve the Fiscal Year 2022-2023 budget. On a motion by Trustee Holloway seconded by Trustee L'Ecluse, the Board unanimously approved these items.

Roll Call Vote:

Trustee Holloway:	AYE	Trustee Johns:	AYE
Trustee L'Ecluse:	AYE	Trustee Shah:	AYE
Trustee Vander Werf:	AYE		

Item No. 8 Fixed Asset and Capitalization Policy: GM Kerr explained that the District's bookkeeper recommended that the District have a fixed asset and capitalization policy in place. On a motion by Trustee Shah seconded by Trustee L'Ecluse, the Board unanimously approved this item.

Roll Call Vote:

Trustee Holloway:	AYE	Trustee Johns:	AYE
Trustee L'Ecluse:	AYE	Trustee Shah:	AYE
Trustee Vander Werf:	AYE		

Item No. 9 Adopt Resolution 2022-10: Levying a Benefit Assessment, Establishing the Rate Thereof and Requesting Collection of Benefit Assessment: On a motion by Trustee Holloway seconded by Trustee L'Ecluse, the Board unanimously approved this item. This item was heard out of order.

Roll Call Vote:

Trustee Holloway:	AYE	Trustee Johns:	AYE
Trustee L'Ecluse:	AYE	Trustee Shah:	AYE
Trustee Vander Werf:	AYE		

Item No. 10 Sacramento County Sheriff's Work Crew Contract: GM Kerr briefed the Board on the benefits of the Sheriff's Work Crew Contract. On a motion by Trustee Johns seconded by Trustee Shah, the motion passed by a 3 to 2 vote.

Roll Call Vote:

Trustee Holloway:	AYE	Trustee Johns:	AYE
Trustee L'Ecluse:	NAY	Trustee Shah:	AYE
Trustee Vander Werf:	NAY		

Item No. 11 Awarding Contract for District Transition to By-District Elections

- a) Redistricting Insights
- b) SCI Consulting Group

GM Kerr discussed with the Board about the two companies who presented last month. On a motion by Trustee Holloway seconded by Trustee L'Ecluse, the Board unanimously selected Redistricting Insights to perform the By-District Elections mapping for the District.

Roll Call Vote:

Trustee Holloway:	AYE	Trustee Johns:	AYE
Trustee L'Ecluse:	AYE	Trustee Shah:	AYE
Trustee Vander Werf:	AYE		

Item No. 12 Authorize General Manger to Request Bids for Rip-Rap Purchase and Delivery: GM Kerr informed the Board that the District would like to purchase Rip-Rap for work along Arcade Creek. On a motion by Trustee L'Ecluse seconded by Trustee Johns, the Board unanimously approved directing staff to request bids for purchase and delivery of Rip-Rap.

Roll Call Vote:

Trustee Holloway:	AYE	Trustee Johns:	AYE
Trustee L'Ecluse:	AYE	Trustee Shah:	AYE
Trustee Vander Werf:	AYE		

Item No. 13 Administrative Staff Reports:

a) *General Manager Tim Kerr reported on the following:*

- General Manager's April Meeting Summary: USACE Erosion O&M meeting was discussed;
- CalTrans American River Bridge Widening Update;
- Hydrologic Conditions: Folsom Lake is 85% of total capacity with an outflow of 1,663 cfs. The gauge at I Street Bridge shows a water surface elevation of 5.5 feet above sea level;
- Next Board Meeting is scheduled for June 10, 2022

b) *Legal Counsel Rebecca Smith:* Assembly Bill 1944 is currently on the docket to permanently allow for Boards to continue hybrid meetings.

c) *Office Manager Malane Chapman:* Informed the Board that the current remote platform does not allow for breakout rooms and the option for participants to phone in. Office Manger Chapman asked the Board if this is of concern or if they would

prefer to continue to have a phone-in option. Trustees expressed that they would like to have a phone-in option but understands if video platforms eliminate the option. Trustee L'Ecluse suggested purchasing an Owl for future meetings.

Item No. 10 Operations and Maintenance Staff Reports:

Field Supervisor Scott Webb:

- Crew activities including mowing, equipment maintenance, camp cleanup, tree work, and heat injury training.

Item No. 11 Questions and Comments by Trustees: Trustee Shah suggested that the Trustees have their personal contact information placed on the website or at a minimum a bio.

Item No. 12 Adjourn: There being no further business requiring action by the Board, the meeting was adjourned by Trustee Shah at 12:58 p.m.

Attest:

Secretary

President

DRAFT

**American River Flood Control District
Staff Report**

Investment Transactions Summary; April 2022

LAIF:

- On April 15, 2022 a quarterly interest deposit was received in the amount of \$52.75.

City Pool A

- Accrued Interest Receivable for the month of April was \$7,133.65.
- As of April 30, 2022, the balance of Interest Receivable in this account was \$70,167.79.

Interest Receivable is accrued and transferred to the Cash Balance at the discretion of the City.

River City Bank Money Market:

- On April 30, 2022 a monthly interest payment was received in the amount of \$83.50.

River City Bank Checking:

- On April 27, 2022 a miscellaneous deposit was received in the amount of \$3,331.25.
- On April 30, 2022 a monthly interest payment was deposited in the amount of \$9.67.
- Total amount of Accounts Payable cleared during the month of April was \$180,904.34.

**American River Flood Control District
Investment Transaction Report
April 2022**

Balance and Transactions

Account		LAIF	City Pool A	River City Bank Money Market	River City Bank Checking
Beginning Balance	4/1/22	\$66,942.22	\$8,932,468.10	\$677,240.51	\$264,869.35
Transactions					
LAIF Interest	4/15/22	\$52.75			
Miscellaneous Deposit	4/27/22				\$3,331.25
City Pool A Interest	4/30/22		\$7,133.65		
River City Bank Interest	4/30/22			\$83.50	\$9.67
Accounts Payable (cleared)					(\$180,904.34)
Ending Balance:	4/30/22	\$66,994.97	\$8,932,468.10	\$677,324.01	\$87,305.93

**City Pool A Interest is accrued and deposited in the account at the discretion of the City.

Interest

Date:	May 2021	June 2021	Jul 2021	Aug 2021
LAIF	0.32	0.26	0.26	0.21
City Pool A	0.93	1.08	1.08	0.92
River City Bank Money Market	0.15	0.15	0.15	0.15
River City Bank Checking	0.08	0.08	0.08	0.08
Date:	Sep 2021	Oct 2021	Nov 2021	Dec 2021
LAIF	0.21	0.20	0.20	0.54
City Pool A	0.88	0.91	0.87	1.08
River City Bank Money Market	0.15	0.15	0.15	0.15
River City Bank Checking	0.08	0.08	0.07	0.08
Date:	Jan 2022	Feb 2022	Mar 2022	Apr 2022
LAIF	0.23	0.28	0.37	0.52
City Pool A	0.83	0.91	0.89	0.96
River City Bank Money Market	0.15	0.15	0.15	0.15
River City Bank Checking	0.08	0.08	0.08	0.07

**American River
Flood Control
District**

AMERICAN RIVER FLOOD CONTROL DISTRICT

MONTHLY REVIEW – APRIL 2022

STRATEGY

The ARFCD funds are invested in the City of Sacramento’s Pool A investment fund. The Fund is invested pursuant to the objectives and requirements set forth in the City’s investment policy. The three objectives of the investment policy, in order of priority, are (1) the preservation of capital by the investment in safe instruments, (2) the liquidity needs of the City and pool participants so such parties will have access to cash when they need it, and (3) the maximizing of current income while remaining consistent with the other more important objectives. The City’s investment policy incorporates applicable provisions of state law including, among other things, the prudent person standard and California Code Section 53601 pertaining to eligible investments.

PORTFOLIO STATISTICS

Beginning Balance	8,995,502
Contributions	0
Withdrawals	0
Interest Earned	7,134
Ending Balance	9,002,636

CITY POOL A PORTFOLIO COMPOSITION

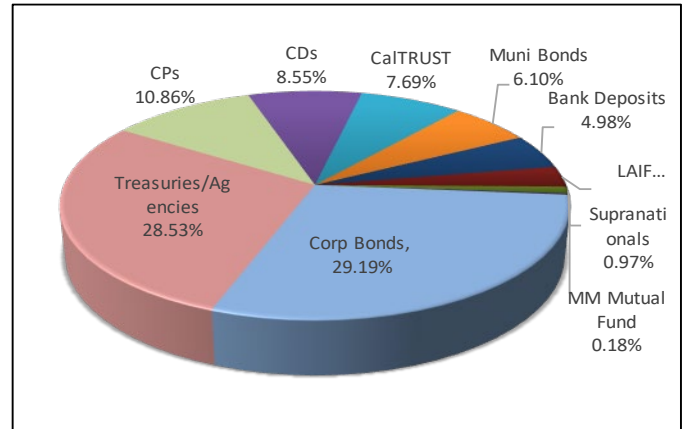

PERFORMANCE COMPARISON

City Pool A	0.96%
LAIF	0.52%
90 Day T-Bill	0.71%
Federal Funds	0.33%

CITY POOL A MATURITY SCHEDULE

Maturity	Market Value	Pct. Holdings
< 1 Year	513,627,702	36.14%
1 - 2 Years	81,346,185	5.72%
2 - 3 Years	91,694,487	6.45%
3 - 4 Years	494,882,209	34.81%
4 - 5 Years	234,960,059	16.53%
5 yrs + 30 dys	4,992,195	0.35%
Total	1,421,502,837	100.00%

Asset Type	Pct. Assets	YTM
Corp Bonds	29.19%	1.53%
Treasuries/Agencies	28.53%	0.87%
CPs	10.86%	0.73%
CDs	8.55%	0.59%
CalTRUST	7.69%	0.64%
Muni Bonds	6.10%	1.64%
Bank Deposits	4.98%	0.35%
LAIF	2.95%	0.52%
Supranationals	0.97%	0.55%
MM Mutual Fund	0.18%	0.03%

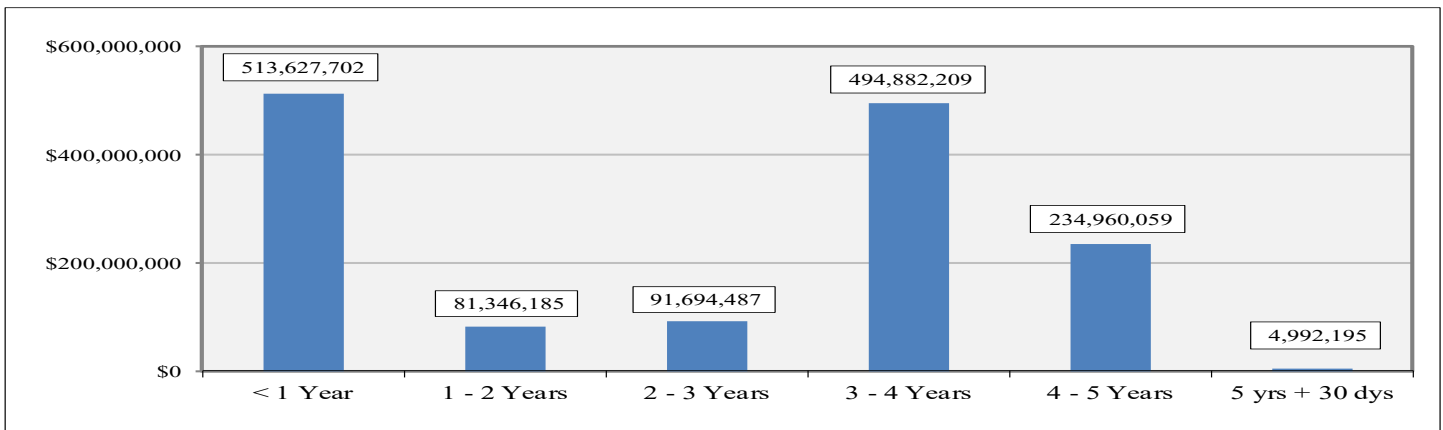

City of Sacramento
 CASH LEDGER
American River Flood Control District
 From 04-01-22 To 04-30-22

All Cash Accounts

Trade Date	Settle Date	Tran Code	Quantity	Security	Amount	Cash Balance
Pool A Interest Receivable						
04-01-22				Beginning Balance		63,034.14
04-30-22	04-30-22	in		Pool A Cash	7,133.65	70,167.79
				Apr 2022 estimated Pool A interest		
					7,133.65	
04-30-22				Ending Balance		70,167.79
Pool A Cash						
04-01-22				Beginning Balance		8,932,468.10
04-30-22				Ending Balance		8,932,468.10

California State Treasurer
Fiona Ma, CPA



Local Agency Investment Fund
 P.O. Box 942809
 Sacramento, CA 94209-0001
 (916) 653-3001

May 02, 2022

[LAIF Home](#)
[PMIA Average Monthly Yields](#)

AMERICAN RIVER FLOOD CONTROL DISTRICT

DISTRICT ENGINEER/MANAGER
 165 COMMERCE CIRCLE, SUITE D
 SACRAMENTO, CA 95815

[Tran Type Definitions](#)

Account Number: 90-34-002

April 2022 Statement

Effective Date	Transaction Date	Tran Type	Confirm Number	Web Confirm Number	Authorized Caller	Amount
4/15/2022	4/14/2022	QRD	1702231	N/A	SYSTEM	52.75

Account Summary

Total Deposit:	52.75	Beginning Balance:	66,942.22
Total Withdrawal:	0.00	Ending Balance:	66,994.97



River City Bank

WWW.RIVERCITYBANK.COM

PO Box 15247, Sacramento, CA 95851-0247

Return Service Requested



Last statement: March 31, 2022
This statement: April 30, 2022
Total days in statement period: 30

AMERICAN RIVER FLOOD CONTROL DISTRICT
C/O ROBERT MERRITT, CPA
4000 MAGNOLIA HILLS DR
EL DORADO HILLS CA 95762-6561

Page 1
0811100952
(0)

Direct inquiries to:
916-567-2836

Public Fund Money Market

Account number	0811100952	Beginning balance	\$677,240.51
Low balance	\$677,240.51	Total additions	83.50
Average balance	\$677,240.51	Total subtractions	0.00
Avg collected balance	\$677,240	Ending balance	\$677,324.01
Interest paid year to date	\$336.40		

CREDITS

Date	Description	Additions
04-30	Interest Credit	83.50

DAILY BALANCES

Date	Amount	Date	Amount	Date	Amount
03-31	677,240.51	04-30	677,324.01		

INTEREST INFORMATION

Annual percentage yield earned	0.15%
Interest-bearing days	30
Average balance for APY	\$677,240.51
Interest earned	\$83.50

OVERDRAFT/RETURN ITEM FEES

	Total for this period	Total year-to-date
Total Overdraft Fees	\$0.00	\$0.00
Total Returned Item Fees	\$0.00	\$0.00



River City Bank

WWW.RIVERCITYBANK.COM

PO Box 15247, Sacramento, CA 95851-0247

Return Service Requested



Last statement: March 31, 2022
This statement: April 30, 2022
Total days in statement period: 30

AMERICAN RIVER FLOOD CONTROL DISTRICT
C/O ROBERT MERRITT, CPA
4000 MAGNOLIA HILLS DR
EL DORADO HILLS CA 95762-6561

Page 1
0811090736
(57)

Direct inquiries to:
916-567-2836

Public Fund Interest Checking

Account number	0811090736	Beginning balance	\$264,869.35
Enclosures	57	Total additions	3,340.92
Low balance	\$84,831.19	Total subtractions	180,904.34
Average balance	\$159,197.68	Ending balance	\$87,305.93
Avg collected balance	\$159,086		

CHECKS

Number	Date	Amount	Number	Date	Amount
8702	04-11	129.00	8768	04-20	3,502.79
8704 *	04-04	500.00	8769	04-19	96.01
8725 *	04-01	612.00	8770	04-19	1,134.36
8749 *	04-06	50.00	8771	04-21	146.27
8750	04-20	30,562.42	8772	04-18	1,099.00
8751	04-20	6,452.07	8773	04-25	198.86
8752	04-26	59.36	8774	04-21	102.33
8753	04-20	683.54	8775	04-29	612.00
8754	04-21	1,236.19	8776	04-19	2,778.57
8755	04-18	450.00	8777	04-21	138.90
8756	04-18	2,003.50	8778	04-19	34.13
8757	04-25	173.12	8779	04-19	159.74
8758	04-20	26.09	8780	04-19	1,077.52
8759	04-25	84.88	8781	04-20	1,275.00
8760	04-19	2,960.00	8782	04-26	1,427.65
8761	04-20	1,188.75	8783	04-20	851.57
8762	04-19	2,735.00	8784	04-19	1,369.27
8763	04-25	85.04	8785	04-19	200.00
8764	04-20	177.52	8786	04-20	1,164.22
8765	04-19	966.34	8787	04-25	203.66
8766	04-19	1,193.95	8788	04-19	2,162.00
8767	04-21	548.70	8789	04-20	98.63

Number	Date	Amount	Number	Date	Amount
8790	04-26	40.42	8797	04-20	2,980.93
8791	04-20	470.70	8798	04-21	388.26
8792	04-25	119.65	8799	04-26	277.83
8793	04-25	643.27	8800	04-20	465.53
8794	04-19	3,189.05	8801	04-28	251.10
8795	04-20	736.69	* Skip in check sequence		
8796	04-19	60.26			

DEBITS

Date	Description	Subtractions
04-01	' ACH Withdrawal INTUIT PAYROLL S QUICKBOOKS 220401 946000047	36,666.11
04-04	' ACH Withdrawal CALPERS 3100 100000016713191	2,789.89
04-04	' ACH Withdrawal CALPERS 1900 100000016757920	3,161.66
04-04	' ACH Withdrawal CALPERS 3100 100000016713150	3,265.10
04-04	' ACH Withdrawal CALPERS 1900 100000016758585	131.67
04-04	' ACH Withdrawal HEALTH EQUITY INC HealthEqui 220404	150.00
04-04	' ACH Withdrawal CALPERS 3100 100000016667892	331.77
04-04	' ACH Withdrawal CALPERS 1900 100000016758577	7,729.00
04-05	' ACH Withdrawal CALPERS 1900 100000016759619	200.00
04-15	' ACH Withdrawal HEALTH EQUITY INC HealthEqui 220415	152.95
04-15	' ACH Withdrawal INTUIT PAYROLL S QUICKBOOKS 220415 946000047	428.23
04-15	' ACH Withdrawal INTUIT PAYROLL S QUICKBOOKS 220415 946000047	34,424.64
04-18	' ACH Withdrawal CALPERS 3100 100000016734533	2,557.42
04-18	' ACH Withdrawal CALPERS 1900 100000016773419	3,105.26
04-18	' ACH Withdrawal CALPERS 3100 100000016734501	3,173.25
04-20	' ACH Withdrawal CALPERS 3100 100000016713169	300.67
04-30	' Service Charge ADDITIONAL DEBITS	3.08

CREDITS

Date	Description	Additions
04-27	Deposit	3,331.25
04-30	Interest Credit	9.67

DAILY BALANCES

Date	Amount	Date	Amount	Date	Amount
03-31	264,869.35	04-15	174,147.33	04-26	84,831.19
04-01	227,591.24	04-18	161,758.90	04-27	88,162.44
04-04	209,532.15	04-19	141,642.70	04-28	87,911.34
04-05	209,332.15	04-20	90,705.58	04-29	87,299.34
04-06	209,282.15	04-21	88,144.93	04-30	87,305.93
04-11	209,153.15	04-25	86,636.45		

INTEREST INFORMATION

Annual percentage yield earned	0.07%
Interest-bearing days	30
Average balance for APY	\$159,086.65
Interest earned	\$9.67

OVERDRAFT/RETURN ITEM FEES

	Total for this period	Total year-to-date
Total Overdraft Fees	\$0.00	\$0.00
Total Returned Item Fees	\$0.00	\$0.00

CERTIFICATION

The American River Flood Control District's investment portfolio [] is [is not] in compliance with the District's Financial Management Investments Plan.

The District's investment portfolio is not in compliance in the following respects:

A cash flow analysis confirms that the District [is] [is not] expected to be able to meet its expenditure requirements for the next six months.

The District's cash is insufficient to meet obligations for the next six months as a result of the following:

Attached hereto are the most recent statements of accounts of the following District accounts:

- LAIF Account, State Treasurer's Office **Dated April 2022**
- Investment Pool A Account, City of Sacramento **Dated April 2022**
- District Checking Account, River City Bank **Dated April 2022**
- District Repurchase Account, River City Bank **Dated April 2022**

Certified by: _____ Date: _____
Rae Vander Werf, District Treasurer

AMERICAN RIVER FLOOD CONTROL DISTRICT
Cash Flow Report
July 2021 through June 2022

Cash Flow Report													
Maintenance and Operations Expens	Jul 21	Aug 21	Sep 21	Oct 21	Nov 21	Dec 21	Jan 22	Feb 22	Mar 22	Apr 22	May 22	Jun 22	TOTAL
500 - Salary/Wages	77,074.32	83,436.34	77,558.58	75,899.43	72,936.34	115,565.03	35,479.01	73,281.98	67,102.02	71,296.50	72,304.57	49,322.42	871,256.54
501 - Payroll Taxes	5,949.26	6,435.99	5,977.50	5,394.53	4,670.94	7,458.11	3,336.04	6,512.11	5,209.00	5,698.96	5,614.29	3,791.89	66,048.62
502 - Pension	17,552.66	19,416.94	17,785.49	17,064.56	20,124.76	15,753.07	(1,224.50)	30,770.71	28,550.19	8,953.52	20,622.18	(1,195.61)	194,173.97
503 - Compensation Insurance	0.00	0.00	0.00	0.00	0.00	0.00	0.00	0.00	0.00	0.00	0.00	0.00	0.00
504 - Medical/Dental/Vision	25,208.54	23,270.36	23,096.36	23,096.36	23,312.36	23,007.86	22,805.94	20,589.28	20,718.28	20,674.32	15,759.06	0.00	241,538.72
508 - Fuel/Oil	3,332.38	5,517.94	7,986.06	4,793.12	3,444.96	2,944.44	3,085.80	3,857.28	1,837.41	6,536.54	6,154.27	0.00	49,490.20
509 - Equipment Rental	479.75	7,842.83	7,578.93	7,578.93	0.00	1,382.00	2,492.99	2,536.84	1,382.87	2,358.17	0.00	0.00	33,633.31
510 - Equipment Purchase(< \$5000	0.00	0.00	0.00	0.00	0.00	579.38	0.00	0.00	0.00	0.00	0.00	0.00	579.38
511 - Equipment Repair/Parts	4,141.11	11,302.28	1,561.57	2,957.74	15,224.90	7,810.13	9,511.59	10,344.97	5,619.94	5,262.47	653.67	0.00	74,390.37
512 - Shop Supplies	1,621.30	2,140.46	434.96	1,991.96	2,367.01	2,365.55	3,377.20	1,204.23	161.04	488.73	755.82	0.00	16,908.26
514 - Levee Maint(Supplies&Materi	1,013.94	187.69	73.34	774.89	1,480.84	74.52	3,990.98	5,388.33	28.44	1,190.01	3,225.41	0.00	17,428.39
515 - Levee Maintenance Services	3,200.90	27,597.20	32,606.16	4,225.16	1,859.96	483.30	0.00	(17,465.46)	0.00	854.24	13,000.00	0.00	66,361.46
516 - Employee Uniforms	0.00	0.00	5,296.49	317.71	0.00	0.00	0.00	0.00	0.00	0.00	0.00	0.00	5,614.20
518 - Staff Training	1,737.37	295.00	299.00	0.00	723.34	229.07	0.00	0.00	0.00	251.10	0.00	0.00	3,534.88
519 - Miscellaneous O&M	0.00	0.00	0.00	0.00	1,188.00	0.00	0.00	0.00	0.00	0.00	0.00	0.00	1,188.00
521 - Small Tools & Equip	0.00	689.56	0.00	2,419.50	0.00	0.00	1,051.62	0.00	1,250.86	853.36	0.00	0.00	6,264.90
523 - Levee Maint. (Chemicals)	0.00	1,038.56	0.00	0.00	1,141.88	18,344.82	0.00	4,302.15	2,175.00	2,778.57	0.00	0.00	29,780.98
525 - Emergency Preparedness Pr	0.00	0.00	0.00	16,800.00	9,504.00	1,275.81	413.47	0.00	0.00	0.00	0.00	0.00	27,993.28
530 - Encroachment Remediation I	0.00	0.00	0.00	0.00	0.00	0.00	0.00	0.00	0.00	0.00	0.00	0.00	0.00
532 - Rodent Abatement	0.00	793.11	0.00	11,291.09	433.92	0.00	0.00	274.58	0.00	0.00	0.00	0.00	12,792.70
533 - Urban Camp Cleanup	1,623.83	1,237.89	1,501.50	830.25	2,764.10	1,110.80	735.61	899.78	1,863.56	1,834.38	1,543.05	0.00	15,944.75
605 - Engineering Services	2,892.00	6,531.20	9,036.81	1,207.75	3,306.01	1,591.20	213.50	276.50	3,163.50	1,099.00	5,544.50	0.00	34,861.97
615 - Survey Services	0.00	185.08	0.00	0.00	0.00	0.00	0.00	0.00	0.00	0.00	0.00	0.00	185.08
616 - Environmental Services/Studi	0.00	0.00	0.00	0.00	0.00	0.00	0.00	0.00	0.00	0.00	0.00	0.00	0.00
Total M&O Expense	145,827.36	197,918.43	190,792.75	176,642.98	164,483.32	199,975.09	85,269.25	142,773.28	139,062.11	130,129.87	145,176.82	51,918.70	1,769,969.96

Administrative Expenses	Jul 21	Aug 21	Sep 21	Oct 21	Nov 21	Dec 21	Jan 22	Feb 22	Mar 22	Apr 22	May 22	Jun 22	TOTAL
505 - Telephone	1,745.21	1,349.82	1,295.50	1,313.50	1,639.41	1,183.95	1,826.62	2,087.79	1,585.34	1,252.87	1,309.11	0.00	16,589.12
506 - Utility Charges	3,023.78	4,738.36	3,848.28	3,936.76	3,975.12	3,552.25	3,333.98	4,857.22	4,161.18	4,663.01	3,729.59	0.00	43,819.53
507 - Office/Shop Lease	0.00	1,224.00	612.00	612.00	612.00	612.00	612.00	612.00	612.00	612.00	612.00	0.00	6,120.00
513 - Office Supplies	0.00	0.00	0.00	0.00	0.00	0.00	0.00	0.00	0.00	0.00	0.00	0.00	0.00
517 - Auto Allowance	550.00	550.00	550.00	550.00	550.00	825.00	275.00	550.00	550.00	550.00	550.00	275.00	6,325.00
520 - Retiree Benefits	11,701.56	11,701.56	11,701.56	11,701.56	11,701.56	10,718.54	10,718.54	9,227.74	9,973.14	9,973.14	9,973.14	0.00	119,092.04
522 - Office Equipment/Furniture	0.00	0.00	0.00	0.00	0.00	0.00	0.00	0.00	1,163.76	0.00	0.00	0.00	1,163.76
526 - Mileage/Parking Reimburs	0.00	0.00	0.00	0.00	0.00	0.00	0.00	0.00	0.00	0.00	0.00	0.00	0.00
527 - General Office Expense	346.66	807.54	2,322.16	860.81	748.23	1,436.06	1,919.22	1,585.26	1,460.56	1,765.08	3,563.18	0.00	16,814.76
529 - Pre-funding Retiree Benefits	0.00	0.00	0.00	0.00	0.00	0.00	0.00	0.00	0.00	0.00	0.00	0.00	0.00
531 - Technology & Software	316.90	698.69	860.49	345.06	346.20	573.70	559.30	386.96	636.19	1,735.66	438.69	0.00	6,897.84
600 - Board of Trustees Compensa	475.00	475.00	380.00	475.00	475.00	475.00	475.00	475.00	380.00	380.00	475.00	0.00	4,940.00
601 - Trustee Expenses	0.00	0.00	0.00	0.00	0.00	62.84	0.00	0.00	0.00	1,350.00	0.00	0.00	1,412.84
602 - Accounting Services	0.00	0.00	0.00	0.00	0.00	400.00	0.00	0.00	0.00	0.00	12,700.00	0.00	13,100.00
603 - Legal Fees (General)	3,360.00	2,015.00	1,024.50	1,741.50	1,444.50	3,219.00	6,128.00	4,266.00	4,070.42	4,738.50	3,456.00	0.00	35,463.42
604 - Flood Litigation	0.00	0.00	0.00	0.00	0.00	0.00	0.00	0.00	0.00	0.00	0.00	0.00	0.00
606 - Legislative Services	0.00	0.00	0.00	0.00	0.00	0.00	0.00	0.00	0.00	0.00	0.00	0.00	0.00
607 - Dues and Assoc. Expens	0.00	0.00	6,097.00	11,313.00	7,615.00	0.00	295.00	0.00	0.00	200.00	0.00	0.00	25,520.00
608 - Insurance Premiums	13,538.17	0.00	0.00	6,832.17	25,397.17	0.00	0.00	0.00	6,851.97	3,120.82	0.00	0.00	55,740.30
609 - Conference /Workshops/Sem	0.00	0.00	0.00	0.00	0.00	0.00	0.00	0.00	0.00	0.00	0.00	0.00	0.00
610 - Public Relations Information	1,903.12	0.00	0.00	0.00	0.00	0.00	18,419.83	0.00	0.00	0.00	0.00	0.00	20,322.95
611 - Election Expenses	0.00	0.00	0.00	0.00	0.00	0.00	0.00	0.00	0.00	0.00	0.00	0.00	0.00
612 - District Annexations	0.00	0.00	0.00	0.00	0.00	0.00	0.00	0.00	0.00	0.00	0.00	0.00	0.00
613 - Community Services	0.00	0.00	0.00	0.00	0.00	0.00	0.00	0.00	0.00	0.00	0.00	0.00	0.00
614 - Miscellaneous Admin	202.57	272.46	232.87	209.33	615.29	299.30	328.48	1,022.14	339.01	599.33	309.19	138.25	4,568.22
617 - Investment Fees	4,442.00	0.00	4,455.00	0.00	4,466.00	0.00	0.00	4,478.00	0.00	0.00	4,488.00	0.00	22,329.00
618 - Property Tax	0.00	0.00	0.00	1,735.34	0.00	0.00	0.00	0.00	0.00	0.00	0.00	0.00	1,735.34
619 - Building Maintenance	0.00	0.00	0.00	0.00	0.00	0.00	0.00	0.00	0.00	0.00	0.00	0.00	0.00
620 - Bookkeeping Services	0.00	1,050.00	1,650.00	637.50	487.50	1,275.00	1,537.50	562.50	412.50	1,275.00	720.00	0.00	9,607.50
621 - County Assessment Fees	0.00	(22,382.36)	0.00	0.00	0.00	0.00	0.00	0.00	0.00	0.00	0.00	0.00	(22,382.36)
622 - County DTech Fees for DLMS	0.00	9,052.08	11,488.48	0.00	0.00	0.00	0.00	10,750.00	0.00	0.00	0.00	0.00	31,290.56

AMERICAN RIVER FLOOD CONTROL DISTRICT
Cash Flow Report
July 2021 through June 2022

623 - Employee Morale/Wellness	4,442.00	0.00	4,455.00	0.00	4,466.00	0.00	0.00	4,478.00	0.00	0.00	4,488.00	0.00	22,329.00
Total Administrative	46,046.97	11,552.15	50,972.84	42,263.53	64,538.98	24,632.64	46,428.47	45,338.61	32,196.07	32,215.41	46,199.90	413.25	442,798.82

Special Projects Expenses	Jul 21	Aug 21	Sep 21	Oct 21	Nov 21	Dec 21	Jan 22	Feb 22	Mar 22	Apr 22	May 22	Jun 22	TOTAL
702 - Engineering/Survey Studies	0.00	0.00	0.00	0.00	0.00	0.00	1,881.00	6,574.00	1,404.00	0.00	0.00	0.00	9,859.00
703 - Encroachment Remediation	0.00	0.00	0.00	0.00	0.00	0.00	0.00	0.00	0.00	0.00	0.00	0.00	0.00
704 - Vegetation Management	0.00	0.00	0.00	0.00	0.00	0.00	0.00	0.00	0.00	0.00	0.00	0.00	0.00
705 - Small Capital Projects	4,748.25	300.00	0.00	0.00	0.00	0.00	0.00	0.00	500.00	0.00	0.00	0.00	5,548.25
707 - Levee Standards Compliance	0.00	0.00	0.00	0.00	0.00	0.00	0.00	0.00	0.00	0.00	0.00	0.00	0.00
Total Special Projects	4,748.25	300.00	0.00	0.00	0.00	0.00	1,881.00	6,574.00	1,904.00	0.00	0.00	0.00	15,407.25

Capital Outlay: Flood Control	Jul 21	Aug 21	Sep 21	Oct 21	Nov 21	Dec 21	Jan 22	Feb 22	Mar 22	Apr 22	May 22	Jun 22	TOTAL
700 - Bank Protection	0.00	0.00	0.00	0.00	0.00	0.00	0.00	0.00	0.00	0.00	0.00	0.00	0.00
701 - Magpie Creek	0.00	0.00	0.00	0.00	0.00	0.00	0.00	0.00	0.00	0.00	0.00	0.00	0.00
706 - Property Acquisition	0.00	0.00	0.00	0.00	0.00	0.00	0.00	0.00	0.00	0.00	0.00	0.00	0.00
709 - Equipment Purchase (> \$500)	0.00	8,303.14	0.00	67,928.52	49,638.82	(7,650.84)	0.00	0.00	0.00	0.00	0.00	0.00	118,219.64
Total Capital Outlay: Flood Control	0.00	8,303.14	0.00	67,928.52	49,638.82	(7,650.84)	0.00	0.00	0.00	0.00	0.00	0.00	118,219.64

Income	Jul 21	Aug 21	Sep 21	Oct 21	Nov 21	Dec 21	Jan 22	Feb 22	Mar 22	Apr 22	May 22	Jun 22	TOTAL
120 - Benefit Assessment	0.00	0.00	0.00	0.00	0.00	18,594.20	738,122.25	0.00	0.00	0.00	516,227.44	0.00	1,272,943.89
122 - SAFCA CAD4	980,000.00	0.00	0.00	0.00	0.00	0.00	0.00	0.00	0.00	0.00	0.00	0.00	980,000.00
123 - Interest	109,121.17	185.08	146.61	161.96	87.92	55.03	97.09	123.91	120.56	145.92	96.90	0.00	110,342.15
124 - O&M Agreements	0.00	0.00	0.00	0.00	0.00	0.00	312,057.20	0.00	0.00	0.00	0.00	0.00	312,057.20
126 - Miscellaneous Income	0.00	0.00	0.00	0.00	0.00	0.00	0.00	0.00	0.00	0.00	0.00	0.00	0.00
Total Income	1,089,121.17	185.08	146.61	161.96	87.92	18,649.23	1,050,276.54	123.91	120.56	145.92	516,324.34	0.00	2,675,343.24

Fund Balance

District Operations Fund	Jul 21	Aug 21	Sep 21	Oct 21	Nov 21	Dec 21	Jan 22	Feb 22	Mar 22	Apr 22	May 22	Jun 22
Beginning Balance	132,508.93	1,375,007.52	1,165,422.02	923,803.04	705,058.49	476,124.11	270,165.61	1,186,863.43	992,301.45	819,259.83	657,060.47	982,008.09
Income	1,439,121.17	185.08	146.61	161.96	87.92	18,649.23	1,050,276.54	123.91	120.56	145.92	516,324.34	0.00
Expenses	196,622.58	209,770.58	241,765.59	218,906.51	229,022.30	224,607.73	133,578.72	194,685.89	173,162.18	162,345.28	191,376.72	124,331.95
Ending Balance	1,375,007.52	1,165,422.02	923,803.04	705,058.49	476,124.11	270,165.61	1,186,863.43	992,301.45	819,259.83	657,060.47	982,008.09	857,676.14

Capital Outlay Reserve Fund

Beginning Balance	920,000.00	920,000.00	920,000.00	920,000.00	920,000.00	920,000.00	920,000.00	920,000.00	920,000.00	920,000.00	920,000.00	920,000.00
Income	0.00	0.00	0.00	0.00	0.00	0.00	0.00	0.00	0.00	0.00	0.00	0.00
Expenses	0.00	0.00	0.00	0.00	0.00	0.00	0.00	0.00	0.00	0.00	0.00	0.00
Ending Balance	920,000.00	920,000.00	920,000.00	920,000.00	920,000.00	920,000.00	920,000.00	920,000.00	920,000.00	920,000.00	920,000.00	920,000.00

Retiree Health Benefit Reserve Fund

Beginning Balance	3,552,014.00	3,552,014.00	3,552,014.00	3,552,014.00	3,552,014.00	3,552,014.00	3,552,014.00	3,552,014.00	3,552,014.00	3,552,014.00	3,552,014.00	3,552,014.00
Income	0.00	0.00	0.00	0.00	0.00	0.00	0.00	0.00	0.00	0.00	0.00	72,000.00
Expenses	0.00	0.00	0.00	0.00	0.00	0.00	0.00	0.00	0.00	0.00	0.00	0.00
Ending Balance	3,552,014.00	3,552,014.00	3,552,014.00	3,552,014.00	3,552,014.00	3,552,014.00	3,552,014.00	3,552,014.00	3,552,014.00	3,552,014.00	3,552,014.00	3,624,014.00

Flood Emergency Response Reserve Fund

Beginning Balance	1,500,000.00	1,500,000.00	1,500,000.00	1,500,000.00	1,500,000.00	1,500,000.00	1,500,000.00	1,500,000.00	1,500,000.00	1,500,000.00	1,500,000.00	1,500,000.00
Income	0.00	0.00	0.00	0.00	0.00	0.00	0.00	0.00	0.00	0.00	0.00	0.00
Expenses	0.00	0.00	0.00	0.00	0.00	0.00	0.00	0.00	0.00	0.00	0.00	0.00
Ending Balance	1,500,000.00	1,500,000.00	1,500,000.00	1,500,000.00	1,500,000.00	1,500,000.00	1,500,000.00	1,500,000.00	1,500,000.00	1,500,000.00	1,500,000.00	1,500,000.00

Emergency Repair Reserve Fund

Beginning Balance	1,500,000.00	1,500,000.00	1,500,000.00	1,500,000.00	1,500,000.00	1,500,000.00	1,500,000.00	1,500,000.00	1,500,000.00	1,500,000.00	1,500,000.00	1,500,000.00
Income	0.00	0.00	0.00	0.00	0.00	0.00	0.00	0.00	0.00	0.00	0.00	0.00
Expenses	0.00	0.00	0.00	0.00	0.00	0.00	0.00	0.00	0.00	0.00	0.00	0.00
Ending Balance	1,500,000.00	1,500,000.00	1,500,000.00	1,500,000.00	1,500,000.00	1,500,000.00	1,500,000.00	1,500,000.00	1,500,000.00	1,500,000.00	1,500,000.00	1,500,000.00

Total Balance	8,847,021.52	8,637,436.02	8,395,817.04	8,177,072.49	7,948,138.11	7,742,179.61	8,658,877.43	8,464,315.45	8,291,273.83	8,129,074.47	8,454,022.09	8,401,690.14
----------------------	---------------------	---------------------	---------------------	---------------------	---------------------	---------------------	---------------------	---------------------	---------------------	---------------------	---------------------	---------------------

American River Flood Control District
Statement of Operations
July 1, 2021 to May 31, 2022 (Eleven Month Ending of Fiscal 2022)
For Internal Use Only

	Year to Date July 1, 2021 to May 31, 2022	Budget	Percent of Budget
Revenues			
Benefit assessment	\$ 1,253,530	\$ 1,429,793	87.67%
Consolidated capital assessment	-	980,000	0.00%
Interest	72,756	77,267	94.16%
O & M agreements	-	231,801	0.00%
Miscellaneous	20,420	-	Not budgeted
Total Revenues	<u>1,346,706</u>	<u>2,718,861</u>	49.53%
M & O Expenses			
Salaries and wages	839,651	890,792	94.26%
Payroll tax expense	62,387	71,263	87.54%
Pension expense	191,681	203,100	94.38%
Compensation insurance	18,471	44,540	41.47%
Medical/dental/vision	260,975	273,642	95.37%
Fuel/oil reimbursement	42,093	35,000	120.27%
Equipment rental	32,890	15,000	219.27%
Equipment repairs/parts	71,204	65,000	109.54%
Equipment purchases (< \$5,000)	1,164	15,000	7.76%
Shop supplies	15,867	27,500	57.70%
Levee maint. (supp. & material)	23,324	20,000	116.62%
Levee maint. chemicals	29,781	35,000	85.09%
Levee maint. services	76,553	80,000	95.69%
Rodent abatement (supplies & materials)	12,793	10,000	127.93%
Employee uniforms	5,614	7,500	74.85%
Staff training	3,240	2,500	129.60%
Regulation Compliance (OSHA)	21,922	20,000	109.61%
Miscellaneous	1,540	2,000	77.00%
Small tools & equipment	6,262	7,500	83.49%
Emergency preparedness program	19,593	35,000	55.98%
Engineering services	25,439	20,000	127.20%
Encroachment remediation	-	15,000	0.00%
Urban camp cleanup	14,334	30,000	47.78%
Total M & O Expenses	<u>1,776,778</u>	<u>1,925,337</u>	92.28%
Administration Expenses			
Board of trustees compensation	5,397	7,600	71.01%
Trustee expenses	63	2,400	2.63%
Trustee training	-	5,000	0.00%
Accounting services	13,800	15,000	92.00%
Legal services (general)	30,088	50,000	60.18%
Utilities	43,154	40,000	107.89%
Telephone	14,489	25,000	57.96%
Retiree benefits	130,005	157,231	82.68%
Office/shop/yard lease	6,120	7,344	83.33%
Office equipment/furniture	-	5,000	0.00%
Auto allowance	6,499	6,600	98.47%
Parking reimbursement	-	500	0.00%
General office expense	11,802	15,000	78.68%
Technology and software	22,857	10,000	228.57%
Dues and associations	25,987	25,000	103.95%
Property and liability insurance	30,479	42,000	72.57%
Public relations/information	18,420	30,000	61.40%
Miscellaneous	4,177	5,000	83.54%
Employee morale/wellness	-	2,000	0.00%
Investment fees	13,432	20,000	67.16%
Community services	-	1,500	0.00%
Bookkeeping services	9,045	14,000	64.61%
Property taxes	1,735	3,000	57.83%
Building maintenance	22,008	10,000	220.08%
County Dtech fees for DLMS	22,238	55,000	40.43%
Interest expense	401	-	Not budgeted
Total Administration Expenses	<u>432,196</u>	<u>554,175</u>	77.99%
Special Projects Expenses			
Engineering studies/survey studies	9,859	170,000	5.80%
Levee standards compliance	-	25,000	0.00%
Small capital projects	5,548	20,000	27.74%
Total Special Project Expenses	<u>15,407</u>	<u>215,000</u>	7.17%
Capital Outlay			
Equipment purchases (over \$5,000)	<u>118,220</u>	<u>162,000</u>	72.98%
Total Capital Outlay	<u>118,220</u>	<u>162,000</u>	
Capital Outlay: District Facilities			
La Riviera improvements/maintenance	<u>-</u>	<u>2,000</u>	0.00%
	<u>-</u>	<u>2,000</u>	

Note: Amounts above are not audited

The above information is current through the last day of the previous month's bank activity.

Data has been verified by the bookkeeper and physical copies of checks have not been reviewed or received and some checks may not have cleared the bank account.

Resolution No. 2022-12

Recognizing and Commending Ross Kawamura for Twenty-Five Years of Valuable Service to the American River Flood Control District

WHEREAS, On May 1, 1997 Ross Kawamura began service as crew member for the American River Flood Control District; and

WHEREAS this year marks his twenty fifth year of faithful service to the residents of this District; and

WHEREAS, during Mr. Kawamura’s tenure, he successfully performed the duties of Field Operations Manager and currently holds the position of Superintendent in which he is responsible for administering the operation and maintenance program for the District’s 40 miles of levee which protect the lives and property of over 400,000 residents, including 160,000 homes, 5,000 businesses, and 1,200 public facilities in the Sacramento area; and,

WHEREAS Mr. Kawamura was part of the American River Flood Control District team which responded to the flood emergencies of January 1997, and again in January 2006 working endless hours under difficult and stressful conditions to insure the flood control system functioned properly to protect the public; and

WHEREAS, under Mr. Kawamura’s watch, the District consistently received ratings of Excellent or Outstanding from the California Department of Water Resources during their biennial inspection of the District’s levee; and

WHEREAS Mr. Kawamura’s demonstrated exemplary leadership and organization in assisting the District in relocating from its prior location and setting up the new facility; and

WHEREAS, Mr. Kawamura’s mechanical expertise with welding, fabrication, and heavy equipment has propelled the District to the forefront of modern levee maintenance; and

WHEREAS, Mr. Kawamura has demonstrated an excellent work ethic and instilled these values in his crew giving a real life definition for the term “leading by example” in the workplace; and

WHEREAS, Mr. Kawamura’s optimistic nature and warm, friendly personality continues to yield vast benefits to the District through his personal outreach with District residents and highly successful efforts to develop relationships with neighbors along the levee; and

WHEREAS, the Board of Trustees of the District realizes and acknowledges the many benefits derived from Richard’s long and faithful service and excellent performance:

NOW, THEREFORE BE IT RESOLVED that the Board of Trustees of the American River Flood Control District does hereby express to Ross Kawamura its sincere appreciation for his long and faithful service and for his dedication to protecting the Sacramento community; and

BE IT FURTHER RESOLVED that the Board directs that this resolution be included in the District’s records and generously be made known to Mr. Kawamura’s many friends and associates.

*American River Flood Control District
Board of Trustees*

Cyril Shah, President

Steven Johns, Vice President

Rae Vander Werf, Treasurer

Tamika L’Ecluse, Secretary

Brian Holloway, Trustee

American River Flood Control District

Request Bids for Removal and Reconstruction of Arcade Creek Floodwall Staff Report

Discussion:

The District's upcoming Arcade Creek Erosion Repair Project requires the placement of rock rip rap along the damaged sections of the bank in Arcade Creek. To facilitate better access to and through the project site, the plan includes removing a section of the Arcade Creek Floodwall to allow truck traffic thoroughfare.

The Arcade Creek floodwall is a reinforced concrete structure that provides necessary freeboard to pass the design water surface. The removal of a 30-foot section of the floodwall needs to be done carefully to not damage the adjacent sections of the wall. Special precautions also should be taken at the time of removal to facilitate effective reinstallation of the wall after the Arcade Creek Erosion Repair Project is complete. Plans for the removal and reinstallation of the wall section were developed by MBK Engineers and AECOM and are attached to this staff report.

Staff seeks to advertise the plans to request bids for a contractor to do the specified floodwall work.

Recommendation:

The General Manager recommends that the Board of Trustees direct staff to advertise an invitation for bids to remove and reconstruct a section of the Arcade Creek floodwall.

CONTRACT DOCUMENTS

AND

SPECIFICATIONS

for the

ARCADE CREEK NORTH LEVEE

FLOODWALL PANEL REMOVAL AND REPLACEMENT PROJECT

June 2022

AMERICAN RIVER FLOOD CONTROL DISTRICT

NORTH AREA STREAMS

City of Sacramento, California

Spec. No. ARFCD-06-22-1

CONTRACT DOCUMENTS AND SPECIFICATIONS

**AMERICAN RIVER FLOOD CONTROL DISTRICT
ARCADE CREEK NORTH LEVEE
FLOODWALL PANEL REMOVAL AND REPLACEMENT PROJECT**

SPECIFICATION No. ARFCD-06-22-1

Prepared by



455 University Avenue, Suite 100
Sacramento, California 95825
(916) 456-4400



AECOM
2020 L Street, Suite 300
Sacramento, CA 95811



Under the direction of
Pro Mitra, Project Engineer



Design Engineer
Joseph H. Barnes, PE

TABLE OF CONTENTS

CONTRACT DOCUMENTS 1

NOTICE INVITING SEALED PROPOSALS 1

INSTRUCTIONS TO BIDDERS..... 3

PROPOSAL FOR ARCADE CREEK NORTH LEVEE FLOODWALL PANEL REMOVAL AND
REPLACEMENT PROJECT 4

ENGINEER’S ESTIMATE..... 7

CONTRACT FORM..... 8

BIDDER’S STATEMENT OF SUBCONTRACTORS, MATERIAL SUPPLIERS AND SERVICES
PROVIDERS 13

SECURITY FOR COMPENSATION CERTIFICATE 14

FAIR EMPLOYMENT PRACTICES 15

NONCOLLUSION AFFIDAVIT 16

PAYMENT BOND..... 17

PERFORMANCE BOND 19

GENERAL PROVISIONS 1

1. General..... 1

 1.1 Definitions and Abbreviations..... 1

2. Examination of Plans, Specifications, Special Provisions, and Site Work 1

3. Proposal Form..... 2

 3.1 Proposal Guarantee 2

4. Rejection of Proposals Containing Alterations, Erasures, or Irregularities..... 2

5. Award of Contract..... 2

6. Responsible Bidder 2

7. Execution of Contract 3

 7.1 Notice to Proceed..... 3

 7.2 Preconstruction Conference..... 3

8. Bonds 3

 8.1 Payment Bond..... 3

 8.2 Performance Bond..... 3

9. Noncollusion Affidavit..... 3

10. Interest in Contract..... 4

11. Assignment 4

12. Audit and Inspection of Records..... 4

13. Change Orders 4

14. Labor Compliance Program Requirements..... 4

 14.1 Notice to Bidders..... 4

 14.2 Instructions to Bidders 5

 14.3 Job Start Meeting..... 5

15. State Labor Provisions – Construction 5

 15.1 Minimum Wages..... 5

 15.2 Non-discrimination in Employment..... 6

 15.3 Travel and Subsistence Payments..... 6

 15.4 Penalty for Paying Less than Prevailing Wage Rates..... 6

 15.5 Payroll Records..... 6

 15.6 Employment of Registered Apprentices..... 6

 15.7 Working Hours 7

 15.8 Workers’ Compensation..... 7

 15.9 License Qualifications of Bidder 7

 15.10 Listing of Subcontractors..... 7

 15.11 Insertion in Subcontracts..... 8

 15.12 State Prevailing Wage Rates..... 8

16. Subcontractors, Material Suppliers and Services Providers 8

17. Bid Items 8

18. Intent of Plans and Specifications..... 8

19. Document Precedence..... 9

20. Interpretations and Requests for Approved Equals/Changes 9

21. Work to Be Done..... 9

22. Alterations..... 9

23. Bid Item Overrun..... 10

24. Extra and Force Account Work 10

25. Progress Payments..... 10

26. Final Payment 11

27. Release of Retention..... 11

28. Public Liability and Property Damage Insurance 11

29. Laws to Be Observed..... 12

30. Permits and Licenses..... 12

31. Safety Provisions 12

32. Public Convenience and Safety..... 12

33. Preservation of Property..... 12

34. Progress of the Work and Time for Completion 13

35. Time of Completion and Liquidated Damages..... 13

36. Temporary Suspension of Work 13

37. Guarantee 13

38. Superintendent 14

39. Lines and Grades..... 14

40. Inspection..... 14

41. Final Inspection 15

42. Dust and Mud Control..... 15

43. Control of Work 15

44. Right-of-Way	15
45. Use of Explosives.....	15
46. Notice of Entrance	16
47. Maintenance of Traffic.....	16
48. Protection of Bridges	16
49. Responsibility for Damage	16
50. Care of Groundwater	16
51. Protection of Contractor’s Work and Property	16
QUALITY CONTROL	1
1. General.....	1
2. Quality Control System	1
2.1 <i>Inspection and Testing</i>	1
2.2 <i>Inadequacies</i>	1
3. Daily Records.....	1
4. Payment	1
5. Inspection and Tests	2
6. Sample of Typical Daily Quality Control Report.....	3
ENVIRONMENTAL PROTECTION	1
1. General.....	1
2. Applicable Regulations.....	1
3. Subcontractors.....	1
4. Coordination and Surveillance.....	1
5. Environmental Protection.....	1
5.1 <i>Completion</i>	1
6. Protection of Land Resources	1
6.1 <i>General</i>	1
6.2 <i>Prevention of Landscape Defacement</i>	2
6.3 <i>Restoration of Landscape Damage</i>	2
6.4 <i>Post-Construction Cleanup or Obliteration</i>	2
7. Recording and Preserving Historical and Archeological Finds.....	2
8. Protection of Water Resources.....	2
8.1 <i>General</i>	2
8.2 <i>Spillages</i>	2
8.3 <i>Disposal</i>	2
9. Protection of Fish and Wildlife	3
10. Payment	3
11. Quality Control.....	3
TECHNICAL PROVISIONS	1
1. General.....	1
1.1 <i>Scope of Work</i>	1

1.2 Type of Contract 1

1.3 Project Location..... 1

1.4 Work to be Performed by the Contractor..... 1

1.5 Water Supply and Sanitation during Construction 2

1.6 Site Access 2

1.7 Contractor's Use of the Premises 2

1.8 Underground Utilities..... 2

1.9 Property Damage 3

1.10 Permits 3

1.11 Project Meetings 3

1.12 Schedule 3

1.13 Superintendence..... 3

1.14 Site Maintenance 3

2. Submittals 3

3. Public Safety..... 4

3.1 Public Safety..... 4

3.2 Transient Population..... 4

4. Demolition and Destruction..... 5

4.1 General..... 5

4.2 Products - Not Applicable..... 5

4.3 Execution..... 5

4.4 Measurement and Payment..... 6

5. CONCRETE REINFORCING..... 6

5.1 GENERAL 6

5.2 PRODUCTS..... 7

5.3 EXECUTION..... 8

5.4 MEASUREMENT AND PAYMENT 9

6. CAST-IN-PLACE CONCRETE..... 9

6.1 General..... 9

6.2 PRODUCTS..... 12

6.3 Execution..... 13

6.4 MEASUREMENT AND PAYMENT 16

7. Cleanup 16

7.1 General..... 16

7.2 Detailed Requirements..... 16

7.3 Final Cleanup of Premises and Work Site..... 16

7.4 Completion 16

7.5 Payment 17

8. Measurement and Payment: 17

8.1 Mobilization/ and Demobilization..... 17

8.2 Flood Wall Demolition and Waste Disposal..... 17

8.3 Provide All Reinforcement and Dowels 17

8.4 Drill and Install Dowels and Vertical Reinforcement..... 17

8.5 Wall Panel Reconstruction 17

8.6 Laboratory Services 18

APPENDIX A LABOR COMPLIANCE PROGRAM 1

APPENDIX B: PROJECT PLANS

CONTRACT DOCUMENTS

NOTICE INVITING SEALED PROPOSALS

NOTICE IS HEREBY GIVEN that American River Flood Control District, hereinafter called the "District", is inviting sealed proposals or bids for "ARCADE CREEK NORTH LEVEE FLOODWALL PANEL REMOVAL AND REPLACEMENT PROJECT."

Sealed bids addressed to "ARCADE CREEK NORTH LEVEE FLOODWALL PANEL REMOVAL AND REPLACEMENT PROJECT," c/o American River Flood Control District, 185 Commerce Circle, Sacramento CA 95815, will be received by mail or hand delivery until 1:00 p.m. on July 1, 2022. The formal bid opening will take place at the offices of American River Flood Control District, 185 Commerce Circle, Sacramento CA 95815, at 1:00 p.m. local time, on July 1, 2022, at which time they will be publicly opened and read.

The project consists of removal and reconstruction of a portion of an existing floodwall along the waterside edge of the levee crown of the Arcade Creek North Levee. The project work will be performed in two phases: The first phase will involve saw-cutting to demolish a 30-foot-long panel in an existing reinforced concrete floodwall that measures 3'-6" high by 8" thick, and transporting and disposing of demolition waste offsite. The removed portion of the floodwall will remain open to allow access to conduct erosion repairs along the north bank of Arcade Creek (by others). The second phase will involve reconstructing the demolished wall panel to preconstruction lines and grades using reinforced concrete. Reconstruction will include drilling and setting dowels to anchor the reconstructed wall panel back into existing concrete on all sides. The second phase of work cannot begin until access to erosion sites no longer require the opening in the floodwall.

Work will be done and progressive payments made in accordance with and as more particularly described in the Specifications and Exhibits.

Bids must be accompanied by a Proposal Guarantee amounting to ten percent (10%) of the bid as described in the Specifications. Said guarantee shall be applied toward any damages sustained by said District in case that bidder depositing the same does not within ten (10) days after written notice that the Contract has been awarded to him, (1) enter into a contract with the District and (2) furnish Performance Bond as described in the Specifications.

The District reserves the privilege of rejecting any and all bids or to waive any irregularities or informalities in any bids or in the bidding procedures, or to postpone the bid opening for good cause.

No bidder may withdraw his bid for a period of thirty (30) days after the date set for opening the bids, within which time an award may be made.

It shall be mandatory upon the Contractor to whom the Contract is awarded and upon any subcontractor under him to pay not less than the specified rates to all workers employed by them in the execution of the Contract work.

The successful bidder, and each of his/her/its subcontractors, shall be required to comply with all local, State, and Federal labor laws and regulations. They shall be required to pay the local prevailing rate of per diem wages as established by the Director of the California Department of Industrial Relations (DIR). Copies of said wage rates are on file at the office of the District, and shall be made available to any interested party, on request.

In accordance with the provisions of section 22300 of the Public Contract Code, the Contractor may elect to receive 100% of payments due under the Contract from time to time, without retention of any portion of the payment, by entering into an Escrow Agreement for Security Deposits in Lieu of Retention.

At the time of Award of Contract, the successful Bidder must be in possession of at least a Class A General Engineering Contractor License issued by the California Contractors State License Board.

An in-person pre-bid site inspection meeting will not be scheduled for this project. The majority of the project area is accessible by the public. All bidders are encouraged to visit the project site prior to bidding. All questions and requests for information can be sent to:

Pro Mitra
c/o MBK Engineers
phone: 916-456-4400
email: mitra@mbkengineers.com

or

Tim Kerr
c/o American River Flood Control District
(916) 929-4006
email: tkerr@arfed.org

Plans and specifications, forms of proposals, bonds and contracts may be obtained at the office of American River Flood Control District, 185 Commerce Circle, Sacramento CA 95815, at a price of \$20.00 per set (non-refundable) (checks made payable to "American River Flood Control District").

Time limit for completion of the work is October 31, 2022.

INSTRUCTIONS TO BIDDERS

1. Bidders must fill out and sign the following documents herein enclosed; failure to do so would constitute a non-responsive bid:
 - Proposal (CD-4, CD-5)
 - Bid Schedule (CD-6)
 - Bidder's Statement of Subcontractors, Material Suppliers and Services Providers (CD-12)
 - Security for Compensation Certificate (CD-13)
 - Fair Employment Practices Certification (CD-14)
 - Noncollusion Affidavit (CD-15)
2. Bids shall be submitted in a sealed envelope, clearly marked on the outside, "ARCADE CREEK NORTH LEVEE FLOODWALL PANEL REMOVAL AND REPLACEMENT PROJECT."
3. Instructions to bidders are hereby made a part of the contract documents.
4. The bidding documents shall not be removed from the purchased bound set of contract documents, including the notice, bidding documents, general conditions, and specific requirements.
5. A signed copy of any addenda issued before the bidding date shall be enclosed with the bid.
6. Prior to submission of bid, Bidders shall visit the site and familiarize themselves with the existing site, construction materials, existing structures, access to the areas of construction, and any other items which may affect their proposals. The submittal of a bid shall be construed that such a visit has been made and that the Bidder has full knowledge of such conditions.
7. To establish a basis for determining the quantities of materials to be handled in this Contract, the Contractor shall review the contract exhibits and bid documents; and he shall perform any calculations or computations he deems necessary to verify the accuracy of the information shown thereon and confirm his agreement in writing to the District upon submittal of his bid.

**PROPOSAL FOR ARCADE CREEK NORTH LEVEE FLOODWALL PANEL
REMOVAL AND REPLACEMENT PROJECT**

Honorable President and Members of the Board
American River Flood Control District
185 Commerce Circle
Sacramento CA 95815

To whom it may concern:

Pursuant to the foregoing Notice Inviting Sealed Proposals, the undersigned hereby proposes and binds himself on award by American River Flood Control District (District) under this proposal, to execute in accordance with such award a contract with necessary bonds of which this proposal, the Notice Inviting Sealed Proposals, and the plans and specifications adopted shall be a part, to furnish any and all labor, material, equipment and services necessary for satisfactorily performing and completing the work set forth in said specifications and shown on the plans accompanying them, within the time hereinafter set forth and at the price named in this proposal and the List of Quantities and Prices.

The undersigned has examined the location of the proposed work and is familiar with the plans, specifications and conditions existing at the site of the work and environs.

The undersigned has checked carefully all the above figures and understands that the District will not be responsible for any errors or omissions on the part of the undersigned in making up this proposal.

The undersigned understands that the quantities as set forth under the foregoing units are approximate only and are for the purpose of comparing bids and fixing the amount of bonds and agrees that these quantities may be increased or decreased, or the relative amounts of the various items varied without claim or damage or loss of anticipated profit, and that payment will only be made on the basis of the actual quantities of work performed.

The undersigned understands that the District reserves the right to reject any and all bids and to waive any informality in bids received and may at its option make the award that in the judgment of the District is to the best interest of the District.

It is agreed that this proposal may not be withdrawn within a period of thirty (30) days after the date set for the opening thereof.

Enclosed herewith is a certificate of fair employment practices, a certificate of Security for Compensation, and a Proposal Guarantee (bidder's bond, certified check, cashier's check) for amount equal to ten percent (10%) of the amount bid (\$_____) and the undersigned agrees that, in case of his default in executing and/or furnishing the necessary bonds after award and due notice thereof, the said check or bond and the money payable thereon shall become and remain the property of the District as liquidated damages.

In accordance with the specifications, the undersigned further agrees to so plan the work and to prosecute it with such diligence that said work shall be commenced within ten (10) days after execution of the Contract by the District and the receipt of a notice from the District to proceed with the work, and shall be completed on or before October 31, 2022.

The undersigned agrees, if awarded the Contract, that there shall be paid by the undersigned and by all subcontractors under him, to all laborers, workmen and mechanics employed in the execution of such Contract or any subcontract thereunder, not less than the general prevailing rate of per diem wages, and rates for overtime and legal holidays in the locality of which the work is to be performed, as ascertained and published by DIR, Division of Standards and Research, a copy of which is on file in the District office.

Name under which business is conducted: _____

Business Address: _____

Zip: _____ Telephone: _____

IF SOLE OWNER, sign here: _____ I sign as sole owner of the business named above.

IF CORPORATION, execute here:

The undersigned certify that they sign this contract proposal with full and proper authorization so to do.

Corporate Name: _____

By: _____ Title: _____

By: _____ Title: _____

Incorporated under the laws of the State of _____

Attachments: Security for Compensation Certificate, Bidders Statement of Subcontractors, (Bidder's Bond, Cashier's Check, or Certified Check).

Date: _____ Contractor's License No.: _____

Expiration Date: _____

Contract No. ARFCD-06-22-1

TO THE BOARD OF TRUSTEES OF AMERICAN RIVER FLOOD CONTROL DISTRICT:

The undersigned declares he has carefully examined the location of the proposed work; that he has examined the plans and specifications and read the accompanying instructions to bidders; and hereby proposes to furnish all materials and do all work required to complete the said work in accordance with the said plans, specifications, and special provisions for the unit price set forth in the following schedule:

CONTRACTOR: _____

ADDRESS: _____

CITY: _____

TELEPHONE NUMBER: _____

CONTRACTOR'S LICENSE NO.: _____ EXP. DATE: _____

BID SCHEDULE					
Bid Item No.	Description of Item	Estimated Quantity	Unit	Unit Price	Total Price of Item
<u>FLOOD WALL PANEL DEMOLITION</u>					
1	MOBILIZATION AND DEMOBILIZATION	1	Each	Lump Sum	
2	DEMOLISH EXISTING FLOOD WALL PANEL	1	Each	Lump Sum	
<u>FLOOD WALL RECONSTRUCTION</u>					
3	MOBILIZATION AND DEMOBILIZATION	1	Each	Lump Sum	
4	PROVIDE ALL REINFORCEMENT AND DOWELS	1	Each	Lump Sum	
5	INSTALL DOWELS AND VERTICAL REBAR	1	Each	Lump Sum	
6	RECONSTRUCT FLOOD WALL	1	Each	Lump Sum	
7	PROVIDE LABORATORY SERVICES	1	Each	Lump Sum	
TOTAL AMOUNT OF BID FOR SCHEDULE #1 (SUM OF ALL BID ITEMS 1-2):					
NOTES:					
1. Work to be as per Specifications and Plans attached hereto. Payment Bond in the amount of 100% of anticipated total contract price must be provided if total contract price is in excess of \$25,000.00 2. Pricing for bid items shall include, but not limited to, permits, fees, labor, equipment, materials, fuel, traffic control, disposal, and bonds					
DATED: _____ CONTRACTOR: _____					

EXHIBIT A

ENGINEER'S ESTIMATE

The Engineer's Cost Estimate for work as described in this contract is between \$50,000 and \$60,000.

Contract No. ARFCD-06-22-1

FORM A-3

CONTRACT FORM

This agreement, made and entered this _____ day of _____, 2022, by and between American River Flood Control District, hereinafter DISTRICT, and _____, hereinafter CONTRACTOR.

For and in consideration of the payments hereinafter specified to be made by DISTRICT, CONTRACTOR agrees at its own proper cost and expense, to do and/or provide the following in accordance with applicable plans and specifications and as directed by DISTRICT:

The project consists of removal and reconstruction of a portion of an existing floodwall along the waterside edge of the levee crown of the Arcade Creek North Levee. The project work will be performed in two phases: The first phase will involve saw-cutting to demolish a 30-foot-long panel in an existing reinforced concrete floodwall that measures 3'-6" high by 8" thick, and transporting and disposing of demolition waste offsite. The removed portion of the floodwall will remain open to allow access to conduct erosion repairs along the north bank of Arcade Creek (by others). The second phase will involve reconstructing the demolished wall panel to preconstruction lines and grades using reinforced concrete. Reconstruction will include drilling and setting dowels to anchor the reconstructed wall panel back into existing concrete on all sides. The second phase of work cannot begin until access to erosion sites no longer require the opening in the floodwall.

Activities should be performed per the plans and specifications entitled "Arcade Creek North Levee Floodwall Panel Removal And Replacement Project," dated June 2022, and per the unit prices shown on Exhibit A.

The total agreed upon price: _____ based on unit prices.

Payment shall be made within sixty (60) days after acceptance of work or portions thereof by DISTRICT or as follows: _____

CONTRACTOR shall provide DISTRICT with payment bond in the amount of \$ _____ in accordance with Civil Code sections 3247 through 3258. No payment will be made by DISTRICT until such bond has been received.

CONTRACTOR shall provide DISTRICT with performance bond in the amount of \$ _____ guaranteeing faithful performance of said Contract.

The complete Contract between the DISTRICT and CONTRACTOR shall consist of the following component parts, to wit: This instrument; the Notice Inviting Bids; the addenda, if any; the accepted Bid Schedule, including all required attached documents; the required bond(s) fully executed; and each of the component parts of the "Contract Documents and Specifications for ARCADE CREEK NORTH LEVEE FLOODWALL PANEL REMOVAL AND REPLACEMENT PROJECT," dated June 2022.

This instrument and the other documents mentioned above constitute the complete Contract between the DISTRICT and CONTRACTOR and the said other documents are as fully a part of this Contract as if hereto attached or herein repeated.

As used herein, "INDEMNIFIED PARTIES" collectively refers to all the following: DISTRICT and its board of trustees, officers, agents and employees; and the State of California, and all of its agencies, departments, officers, agents and employees, including but not limited to the Central Valley Flood Protection Board and the Department of Water Resources and their respective officers, agents and employees.

Contract No. ARFCD-06-22-1

FORM A-3

CONTRACTOR shall be responsible for its own work, property, and/or materials until completion and final acceptance of the work by the DISTRICT. In the event of loss or damage, it shall proceed promptly to make repairs or replacement of the damaged work, property, and/or materials at its own expense, as directed by the DISTRICT. CONTRACTOR waives all rights CONTRACTOR might have against DISTRICT for loss of or damage to CONTRACTOR's work, property, or materials. Payment shall not be construed as a waiver of this or of any other terms of the Contract.

CONTRACTOR shall pay for all material, labor, taxes, insurance and other claims, liabilities, and obligations of any nature arising from any aspect of its work performed under this Contract and shall furnish satisfactory evidence of such payments upon request of DISTRICT. CONTRACTOR agrees to indemnify, defend, and hold harmless INDEMNIFIED PARTIES from all suits, liens, or other claims of any nature arising from its failure to make such payments.

CONTRACTOR shall provide and maintain at all times during the performance the following insurance:

Workers' Compensation insurance meeting the requirements of both the State of California and the Federal Longshore and Harbor Workers' Compensation Act to the extent applicable.

Insurance covering Public Liability, Property Damage, and Contractor's Contractual Liability arising out of or relating to CONTRACTOR's performance hereunder (all including but not limited to work performance and the operation of automobiles, trucks and other vehicles) in amounts of not less than \$1,000,000 per occurrence, protecting CONTRACTOR and INDEMNIFIED PARTIES against liability for damages because of injuries (including death) and in an amount of not less than \$1,000,000 per occurrence against liability for damages to property. All of the following shall be named as additional insureds on said policies: "American River Flood Control District and its board of trustees, officers, agents and employees; and the State of California, and all of its agencies, departments, officers, agents and employees."

All insurance required hereunder shall be maintained in full force and effect in a company or companies satisfactory to DISTRICT, shall be maintained at CONTRACTOR's expense until performance in full hereof and such insurance shall be subject to requirement that DISTRICT must be notified by thirty (30) days' written notice before cancellation of any such policy. In the event of threatened cancellation for non-payment of premium, DISTRICT may pay same for CONTRACTOR and deduct the same payment from amounts then or subsequently owing to CONTRACTOR hereunder.

Evidence of such insurance shall be furnished by CONTRACTOR to DISTRICT upon request.

CONTRACTOR specifically obligates itself to DISTRICT in the following respects (and this agreement is made upon such express condition), to wit:

CONTRACTOR shall protect and keep INDEMNIFIED PARTIES harmless and free from all liability, penalties, losses, damages, costs, expenses, causes of action, claims and judgments resulting from injury or harm to any person or property arising out of or in any way connected with the performance hereof.

Contract No. ARFCD-06-22-1

FORM A-3

CONTRACTOR shall further hold INDEMNIFIED PARTIES harmless from liability or claims for any injuries to or death of CONTRACTOR's employees resulting from any cause whatsoever, and shall indemnify INDEMNIFIED PARTIES for any cost, expense or judgment (including attorney's fees) paid or incurred in that behalf.

CONTRACTOR shall be fully and exclusively responsible for and shall pay when due any and all applicable contributions, allowances or other payments or deductions, however termed, required by union labor agreements now or hereafter in force.

CONTRACTOR shall indemnify INDEMNIFIED PARTIES against, and save them harmless from any and all loss, damage, costs, expenses and attorney's fees suffered or incurred on account of any breach of the aforesaid obligations and covenants, and any other provisions or covenants of this Contract.

At any time before final settlement or adjudication of any loss, damage, liability, claim, demand, suit or cause of action for which CONTRACTOR hereby agrees to indemnify and save INDEMNIFIED PARTIES harmless, DISTRICT may withhold from any payments due or to become due under this Contract the reasonable value thereof, as determined by DISTRICT.

CONTRACTOR specifically agrees that it is, or prior to the start of work hereunder will become, a CONTRACTOR and an employing unit subject as an employer, to all applicable Unemployment Compensation Statutes.

CONTRACTOR further agrees as regards (a) the production, purchase and sale, furnishing and delivering, pricing, and use or consumption of materials, supplies and equipment; (b) the hire, tenure or conditions of employment of employees and their hours of work and rates of and the payment of their wages; and (c) the keeping of records, making of reports, and the payment, collection, and/or deduction of Federal, State and Municipal taxes and contributions that CONTRACTOR will keep and have available all necessary records and make all payments, reports, collections, deductions, and otherwise do any and all things so as to fully comply with all Federal, State and Municipal laws, ordinances, regulations, and requirements in regard to any and all said matters insofar as they affect or involve the CONTRACTOR's performance of this Contract, all so as to fully relieve INDEMNIFIED PARTIES from and protect it against any and all responsibility or liability therefore or in regard thereto.

CONTRACTOR further agrees as to comply with California Labor Codes including, but not limited to:

- Pursuant to Labor Code section 1771 for contracts over \$1,000.00, this District works with the Compliance Monitoring Unit/Division of Labor Standards Enforcement and requires that all contractors and subcontractors working on this project keep certified payroll records in accordance with Labor Code section 1776, and to submit electronically via the Department of Industrial Relations (DIR) Compliance Monitoring Unit website. For any questions please email CMU@dir.ca.gov or call 916-263-1811.
- Pursuant to Labor Code section 1771.1, a contractor or subcontractor shall not be qualified to bid on, be listed in a bid proposal, subject to the requirements of section 4104 of the Public Contract Code, or engage in the performance of any contract for public work, unless currently registered with DIR and qualified to perform public work pursuant to section 1725.5.

Contract No. ARFCD-06-22-1

FORM A-3

- In accordance with the provisions of Labor Code section 1720 et seq., the Division of Labor Standards and Research has determined the general prevailing rates or wages and employer payments for health and welfare, pension, vacation, travel time, and subsistence pay as provided for in Labor Code section 1773.8.
- It shall be mandatory upon the CONTRACTOR herein and upon any subcontractor to pay not less than the said specified rates to all laborers, workers, and mechanics employed by them in the execution of the Agreement pursuant to Labor Code section 1774.
- The CONTRACTOR shall post job site notices, as prescribed by regulation 1771.4(a)(2).

The District or District Representative shall make periodic site visits to observe and interview workers regarding the payment of prevailing wages and proper work classifications. CONTRACTOR and each subcontractor shall cooperate and coordinate with the District and provide unaccompanied access to workers on the job site.

Attention is directed to the provisions in sections 1777.5 and 1777.6 of the Labor Code concerning the requirement to employ apprentices by the CONTRACTOR or any subcontractor under it.

CONTRACTOR and any subcontractors shall be assessed penalties for violating Labor Code sections as stated above and as specified in the Code.

CONTRACTOR certifies that he is aware of the provisions of section 3700 of the Labor Code, which require every employer to be insured against liability for workers' compensation or to undertake self-insurance in accordance with the provisions of that code, and that he will comply with such provisions before commencing the performance of the work of this Contract.

This agreement shall not be modified except by written document executed by the parties hereto.

CONTRACTOR

American River Flood Control District

By: _____

By: _____

Title: _____

Title: _____

**BIDDER'S STATEMENT OF SUBCONTRACTORS, MATERIAL SUPPLIERS
AND SERVICES PROVIDERS**

The undersigned submits herewith a list of subcontractors, material suppliers and services providers whom he proposes to employ on the work, with the proper firm name and business address of each, together with a statement of the portion and percentage of the work to be done by each.

Name of Subcontractor/Supplier/Provider	Address	Email Address	Portion and % of Work
1.			
2.			
3.			
4.			
5.			
6.			
7.			

Check if none proposed.

Signature of Bidder

SECURITY FOR COMPENSATION CERTIFICATE

TO: _____

I am aware of the provisions of section 3700 of the California Labor Code, which requires every employer to be insured against liability for workers' compensation or to undertake self-insurance in accordance with the provisions of that Code, and I will comply with such provisions before commencing the performance of the work of this Contract.

Signature of Bidder

Business Address _____

Place of Residence _____

(This certification must be executed by the successful bidder prior to the award of contract. The bidder shall execute the certification on the page at the time of submitting his or her bid.)

FAIR EMPLOYMENT PRACTICES

TO: _____

The undersigned in submitting a bid for performing the following work by contract, hereby certifies that he has or will meet the standards of affirmative compliance with the Fair Employment Practices requirements of the Special Provisions contained herein.

(fill in description of contract)

Signature of Bidder

Business Address _____

Place of Residence _____

(This certification must be executed by the successful bidder prior to the award of contract. The bidder shall execute the certification on the page at the time of submitting his or her bid.)

NONCOLLUSION AFFIDAVIT

_____, being first duly sworn, deposes and says that he/she is _____ of the party making the foregoing bid; that the bid is not made in the interest of, or on behalf of, any undisclosed person, partnership, company, association, organization, or corporation; that the bid is genuine and not collusive or sham; that the bidder has not directly or indirectly induced or solicited any other bidder to put in a false or sham bid, and has not directly or indirectly colluded, conspired, connived, or agreed with any bidder or anyone else to put in a sham bid, or that anyone shall refrain from bidding; that the bidder has not in any manner, directly or indirectly, sought by agreement, communication, or conference with anyone to fix the bid price of the bidder or any other bidder, or to fix any overhead, profit, or cost element of the bid price, or of that of any other bidder, or to secure any advantage against the public body awarding the contract of anyone interested in the proposed contract; that all statements contained in the bid are true; and, further, that the bidder has not, directly or indirectly, submitted his or her bid price or any breakdown thereof, or the contents thereof, or divulged information or data relative thereto, or paid, and will not pay, any fee to any corporation, partnership, company association, organization, bid depository, or to any member or agent thereof to effectuate a collusive or sham bid.

I declare under penalty of perjury under the laws of the State of California that the foregoing is true and correct.

Executed this date _____, 2022, at _____.

NAME OF BIDDER: _____

SIGNATURE OF: _____

NAME/TITLE: _____

PAYMENT BOND

KNOW ALL MEN BY THESE PRESENTS, that

WHEREAS, American River Flood Control District (hereinafter referred to as "District") and _____
_____ (hereinafter referred to as "Principal") have entered into a contract for
the construction of the ARCADE CREEK NORTH LEVEE FLOODWALL PANEL REMOVAL AND REPLACEMENT
PROJECT; and

WHEREAS, under the terms of said contract Principal is required to furnish a bond securing payment of
the claims to which reference is made in section 3248 of the Civil Code;

NOW, THEREFORE, we, the Principal, and _____

as Surety, are held and firmly bound unto the District in the penal sum of _____

dollars (\$ _____) lawful money of the United States, being not less than one hundred
percent (100%) of the amount payable by the terms of the contract, for the payment of which sum well
and truly to be made we bind ourselves, our heirs, executors, administrators and successors, jointly and
severally, firmly by these presents.

The condition of this obligation is such that if said Principal or any of its subcontractors fails to pay any of
the persons named in section 3181 of the Civil Code, or amounts due under the Unemployment Insurance
Code with respect to work or labor performed under the Contract, or for any amounts required to be
deducted, withheld, and paid over to the Franchise Tax Board from the wages of employees of the
Principal or its subcontractors pursuant to section 18806 of the Revenue and Taxation Code, with respect
to such work and labor that the Surety will pay for the same, in an amount not exceeding the amount
hereinabove set forth and also will pay, in case suit is brought upon this bond, a reasonable attorney's
fee, to be fixed by the court.

This bond shall inure to the benefit of any of the persons named in section 3181 of the Civil Code so as to
give a right to action to such persons or their assigns in any suit brought upon this bond.

This bond is given to comply with sections 3247 and 3248 of the Civil Code. The liability of the Principal
and Surety hereunder is governed by the provisions of said Code, all acts amendatory thereof, and all
other statutes referred to therein, including section 3225 of the Civil Code.

The Surety hereby stipulates and agrees that no change, extension of time, alteration or addition to the
terms of the contract or to the work to be performed thereunder or the specifications accompanying the
same shall in any wise affect its obligation of this bond, and it does hereby waive notice of any such
change, extension of time, alteration or addition to the terms of the Contract or to the work or to the
specifications.

IN WITNESS WHEREOF, the above bounded parties have executed this instrument under their seals this _____ day of _____, 2022, the name and corporate seal of each corporate body being hereto affixed and these presents duly signed by its undersigned representative, pursuant to authority of its governing body.

Note:

(Principal)

To be signed by Principal
and Surety and acknowledgement
and notarial seal attached.

By: _____

By: _____

(Surety)

By: _____

By: _____

PERFORMANCE BOND

KNOW ALL MEN BY THESE PRESENTS, that

WHEREAS, American River Flood Control District (hereinafter referred to as "District") has entered into a contract with _____ (hereinafter referred to as "Principal") for the ARCADE CREEK NORTH LEVEE FLOODWALL PANEL REMOVAL AND REPLACEMENT PROJECT; and

WHEREAS, said Principal is required under the terms of said contract to furnish a bond of faithful performance of said Contract;

NOW, THEREFORE, we, the Principal, and _____, as Surety, are held and firmly bound unto the District in the penal sum of _____ dollars (\$ _____) lawful money of the United States, being a sum equal to the total amount payable under the contract, for the payment of which sum, well and truly to be made, we bind ourselves, our heirs, executors, administrators and successors, jointly and severally, firmly by these presents.

THE CONDITION OF THIS OBLIGATION IS SUCH that if the above bounded Principal shall in all things stand to and abide by and well and truly keep and perform the covenants, conditions and agreements in the said contract and any alteration thereof made as therein provided, on his part to be kept and performed at the time and in the manner therein specified, and in all respects according to their true intent and meaning, as therein stipulated, then this obligation shall become null and void; otherwise it shall be and remain in full force and virtue.

As a condition precedent to satisfactory completion of the said contract, the above obligations to the amount of _____ dollars (\$ _____) being not less than ten percent (10%) of the total amount payable under the contract, shall hold good for a period of ninety (90) days after the completion and acceptance of said work, during which time if the above bounded Principal shall fail to make full, complete and satisfactory repair and replacement or totally protect the District from loss or damage made evident during said period of ninety (90) days from the date of acceptance of said work, and resulting from or caused by defective materials or faulty workmanship in the prosecution of the work done, the above obligation in the said sum of _____ dollars (\$ _____) shall remain in full force and virtue; otherwise the above obligation shall be void.

And the said Surety, for value received, hereby stipulates and agrees that no change, extension of time, alteration or addition to the terms of the Contract or to the work to be performed thereunder or the Specifications accompanying the same shall in any wise affect its obligations on this bond, and it does hereby waive notice of any such change, extension of time, alteration or addition to the terms of the Contract or to the work or to the Specifications.

In the event that the District, or its successors or assigns, shall be the prevailing party in an action brought upon this bond, then in addition to the penal sum herein above specified, we agree to pay to the District or its successors or assigns, a reasonable sum on account of attorney's fees in such action, which sum shall be fixed by the court.

IN WITNESS WHEREOF, the above bounded parties have executed this instrument under their seals this _____ day of _____, 2022, the name and corporate seal of each corporate party being hereto affixed and these presents duly signed by its undersigned representative, pursuant to authority of its governing body.

Note:

(Principal)

To be signed by Principal
and Surety and acknowledgement
and notarial seal attached.

By: _____

By: _____

(Surety)

By: _____

By: _____

GENERAL PROVISIONS

1. GENERAL

The project consists of removal and reconstruction of a portion of an existing floodwall along the waterside edge of the levee crown of the Arcade Creek North Levee. The project work will be performed in two phases: The first phase will involve saw-cutting to demolish a 30-foot-long panel in an existing reinforced concrete floodwall that measures 3'-6" high by 8" thick, and transporting and disposing of demolition waste offsite. The removed portion of the floodwall will remain open to allow access to conduct erosion repairs along the north bank of Arcade Creek (by others). The second phase will involve reconstructing the demolished wall panel to preconstruction lines and grades using reinforced concrete. Reconstruction will include drilling and setting dowels to anchor the reconstructed wall panel back into existing concrete on all sides. The second phase of work cannot begin until access to erosion sites no longer require the opening in the floodwall.

1.1 Definitions and Abbreviations

For the purposes of these specifications, the following definition and abbreviation of terms apply:

"Contractor" – Party entering into contract with the District for the performance of work covered by this contract, and his authorized agents or legal representatives.

"Day" or "days" – Unless herein otherwise expressly defined, shall mean a calendar day or days of 24 hours each.

"District" – American River Flood Control District as the contracting entity for the work specified herein.

"Inspector" – Engineering or technical inspector(s) duly authorized or appointed by the District or District, limited to the particular duties entrusted to him or them.

"Landside slope" – The slope or face of the levee embankment on the opposite side of the levee crown from a river, slough, bay or other watercourse.

"Waterside slope" – The slope or face of the levee embankment adjacent to a river, slough, bay or other watercourse.

2. EXAMINATION OF PLANS, SPECIFICATIONS, SPECIAL PROVISIONS, AND SITE WORK

The bidder is required to examine carefully the site, proposal, plans, specifications, and contract forms for the work contemplated, and it will be assumed the bidder has investigated and is satisfied as to the conditions to be encountered, as to the character, quality, and quantities of work to be performed and materials to be furnished, as to the requirements of the specifications, the special provisions, and the contract. It is mutually agreed that submission of a proposal shall be considered prima facie evidence that the bidder has made such examination.

The bidder shall receive no additional compensation for any obstacle or difficulties due to surface or subsurface conditions actually encountered. Where investigations of surface or subsurface conditions have been made by the District in respect to foundation or other structural design, and that information is shown in the plans, said information is included only for the convenience of bidders. The District assumes no responsibility whatsoever as to the sufficiency or accuracy of borings, or of the logs of test borings or other investigations or tests, or of the interpretation thereof; there is no guarantee, warranty

or representation, express or implied, that the conditions indicated thereby in fact exist or are representative of those existing throughout the work. Such information shall be used as a basis for bids at the bidder's own and sole risk; making such information available to bidders is not to be construed in any way as a waiver of the other provisions of this paragraph, and bidders must satisfy themselves through their own investigation as to the surface and subsurface conditions to be encountered at the site.

3. PROPOSAL FORM

All proposals must be made upon the Bid Form attached to these specifications.

All proposals must give the prices proposed and must be signed by the bidder, with his address. If the proposal is made by an individual, his name and post office address must be shown. If made by a firm or partnership, the name and post office address of each member of the firm or partnership must be shown. If made by a corporation, the proposal must show the name and state under the laws of which the corporation was chartered and the names, titles, and business addresses of the president, secretary, and treasurer.

3.1 Proposal Guarantee

Each bidder shall furnish a bid guarantee in the amount of 10% of the bid price. The bid guarantee shall be in the form of a firm commitment, such as a bid bond, postal money order, certified check, cashier's check or irrevocable letter of credit. The District will return bid guarantees, other than bonds to unsuccessful bidders as soon as practicable after the opening of bids and to the successful bidder upon execution of contractual documents and bonds as required by the bid as accepted.

4. REJECTION OF PROPOSALS CONTAINING ALTERATIONS, ERASURES, OR IRREGULARITIES

Proposals may be rejected if they show any alterations of form, additions not called for, conditional or alternative bids, incomplete bids, erasures, or irregularities of any kind.

5. AWARD OF CONTRACT

All bids will be compared on the basis of the District's estimate of quantities of work to be done. The award of the contract, if it be awarded, will be to the lowest responsible bidder whose proposal complies with all the requirements described. The award, if made, will be made within thirty (30) days after the opening of the bids; Contractor's bid shall remain valid for at least thirty (30) days.

6. RESPONSIBLE BIDDER

The District reserves the right to reject the bid of any Bidder who in the opinion of the Board of Trustees is not responsible or has previously failed to perform properly, or to complete on time, contracts of a similar nature, is not in a position to perform the contract, or has habitually and without just cause neglected the payment of bills or otherwise disregarded his obligations to subcontractors, materialmen, or employees. In determining if a bidder is responsible, the following elements, in addition to those mentioned above, will be considered, to wit: whether the Bidder involved (1) maintains a permanent place of business, (2) has adequate plant and equipment available to do work properly and expeditiously, (3) has suitable financial resources to meet the obligations incident to the work, and (4) has appropriate experience.

The Bidder may be required, prior to execution of a contract and upon request of the District, to prove to the District's satisfaction that he has the skill and experience and that he has the necessary facilities and ample financial resources to perform the Contract in a satisfactory manner and within the required time.

7. EXECUTION OF CONTRACT

The Contract shall be signed by the successful bidder and returned, together with any applicable bonds, within ten (10) days, after the bidder has received notice that the Contract has been awarded. No proposal shall be considered binding upon the District until the execution of the Contract.

Failure to execute a contract and file acceptable bonds as provided herein within ten (10) days, after the bidder has received notice that the Contract has been awarded, shall be just cause for the annulment of the award. The bid guarantee will become and remain the property of the District as liquidated damages.

7.1 Notice to Proceed

Upon successful completion of provisions number 7 above and number 8 below, the District shall issue a written Notice to Proceed to Contractor.

7.2 Preconstruction Conference

Subsequent to receiving Notice to Proceed and prior to start of construction, the Contractor and District shall attend a Preconstruction Conference to finalize project plans and scheduling.

8. BONDS

8.1 Payment Bond

Payment Bond in the amount complying with Civil Code section 3247 et seq. must accompany contract to be awarded. This Labor & Materials Bond must be provided if the total contract price is in excess of \$25,000.00. The bond must be in the amount of 100 percent of the anticipated total contract price. Said bond shall be in the form furnished by the District herein.

8.2 Performance Bond

As part of the execution of this contract, the Contractor shall furnish and bear the cost of a bond of a surety company acceptable to the District, which bond is conditioned upon the faithful performance of all covenants and stipulations under this contract. The amount of the bond shall be one hundred percent (100%) of the total Contract price, as such sum is set forth in the agreement. Said bond shall be on the form furnished by the District herein.

9. NONCOLLUSION AFFIDAVIT

If at any time it shall be found that the person, firm or corporation to whom a contract has been awarded has, in presenting any bid or bids, colluded with any other party or parties, then the Contract so awarded shall be null and void and the Contractor and his bondsmen shall be liable to the District for all loss or damage which the District may suffer thereby and the Board of Trustees may call for new bids.

The Bidder's attention is called to the fact that a Bid is not complete and will not be considered for any purpose unless the Noncollusion Affidavit is completely executed and submitted as a part of the Bidder's Bid package.

10. INTEREST IN CONTRACT

The Bidder shall represent and warrant that neither the General Manager, nor any Director, Trustee, officer, or employee of the District is in any manner interested, directly or indirectly, in the bid or in the Contract which may be made under it, or any expected profits to arise therefrom. This section shall not apply to Contracts awarded to a corporation in which the only interest of the General Manager, or any Director, officer, or employee, is the ownership of less than one percent (1%) of the entire capital stock of said corporation.

No member or delegate to the Congress of the United States shall be admitted to any share or part of this Contract or to any benefit arising therefrom.

No member, officer, or employee of the public body or of a local public body during his tenure or for one year thereafter shall have any interest, direct or indirect, in this Contract or the proceeds thereof.

Under this section, a restricted individual will not be deemed to have an interest in the Contract awarded to a corporation if his/her only interest is the ownership of less than one percent (1%) of the entire capital stock of said corporation.

11. ASSIGNMENT

The Contractor shall not assign, transfer, convey, sublet or otherwise dispose of the Contract or his right, title, or interest in or to the same or any part hereof without prior consent, in writing, of the District, endorsed thereon or attached thereto.

12. AUDIT AND INSPECTION OF RECORDS

The Contractor shall permit the authorized representatives of the District to inspect and audit all data and records of the Contractor and any subcontractor relating to the performance under this Contract from the date of the Contract through and until the expiration of three (3) years after completion of the Contract. The inspection and audit provided in this section does not include an audit of the manufacturer's cost and/or profit, with the exception of single bid or sole source situations.

13. CHANGE ORDERS

Any proposed change in the Contract shall be submitted to the District for its prior approval. Such change shall be made by a Change Order, wherein the change shall be specifically described, including a statement as to the effect of the change on the Contract price, if any, and the time for completion. No change order is valid unless approved and signed by the District.

14. LABOR COMPLIANCE PROGRAM REQUIREMENTS

14.1 Notice to Bidders

This Contract is subject to prevailing wage compliance monitoring and enforcement by the Department of Industrial Relations (DIR). Pursuant to California Labor Code section 1725.5, all contractors and subcontractors must be currently registered and be in good standing with DIR to be listed on a bid and work on a public works project. A Bidder that is not a DIR-registered contractor when submitting a bid for the Contract work is deemed "not qualified." Prime Contractors, subcontractors of any tier, and services providers subject to prevailing wage requirements shall be registered with DIR at all times during the

performance of the work. The prime Contractor shall independently verify the registration status of each entity during the performance of the work. All Contractors must electronically submit their payroll to the Labor Commissioner, and for some projects, depending on funding source, submit payroll to a third-party labor compliance administrator.

In accordance with the provisions of sections 1770 and 1773 of the Labor Code, the Director of DIR has determined the general prevailing rate of wages applicable to the work to be done. These rates are set forth in a schedule located at DIR. This schedule is available to any interested party on request. Attention is directed to the provisions of sections 1777.5 and 1777.6 of the Labor Code of the State of California concerning employment of apprentices by the Contractor or a subcontractor. Each prime Contractor and all subcontractors are responsible for compliance with the requirements of sections 1777.5 and 1777.6.

14.2 Instructions to Bidders

The Contractor and all subcontractors are required to comply with all Labor Code requirements. Certified payroll records need to be electronically submitted to the Labor Commissioner and if applicable they need to be submitted to the District's third-party labor compliance reviewer. These records are to be submitted on a weekly basis.

Contractors will receive mandatory project posters from the awarding agency. Contractors are required to display the poster at the job site. The poster will include contact information for the nearest Division of Labor Standards Enforcement Office (Labor Commissioner's Office).

The District will conduct a pre-job conference before commencement of the work with contractors and subcontractors listed in the bid or who are required to be identified or prequalified in a Design-Build Contract. At the pre-job conference, applicable Federal and State labor law requirements shall be discussed. A checklist showing which Federal and State labor law requirements were discussed, shall be kept for each conference. The attached checklist in Appendix A (following section 16421 in subchapter 4 of these regulations) meets this requirement.

The District shall withhold Contract payments when payroll records are delinquent or inadequate. The District shall withhold Contract payments equal to the amount of underpayment, with penalties, when it has been established after investigation that underpayment has occurred.

14.3 Job Start Meeting

The District will conduct a labor compliance pre-job meeting ("Job Start Meeting") which is mandatory for all Contractors and subcontractors. The District's Labor Compliance Program will be discussed with all in attendance. The Job Start Meeting will discuss the payment of prevailing wages, apprenticeship training, penalties, and certified payroll records; as well as non-discrimination in employment, kickbacks, acceptance of prohibited fees, proper licensing, unfair competition, and workers' compensation insurance.

15. STATE LABOR PROVISIONS – CONSTRUCTION

15.1 Minimum Wages

All mechanics and laborers employed or working upon the site of the work shall be paid not less than the local prevailing rate of per diem wages, as established by DIR, applicable to this project.

15.2 Non-discrimination in Employment

The Contractor will not discriminate against any employee or applicant for employment because of race, religious creed, color, national origin, ancestry, physical disability, mental disability, medical condition, marital status, sex or sexual orientation, except as may be provided in section 12940 of the Government Code of the State of California.

15.3 Travel and Subsistence Payments

The Contractor shall be required to make such travel and subsistence payments to each worker needed to execute the work, as such travel and subsistence payments are defined in the applicable collective bargaining agreement filed with DIR in accordance with section 1773.1 of the Labor Code of the State of California.

15.4 Penalty for Paying Less than Prevailing Wage Rates

In accordance with California Labor Code section 1775 the Contractor shall, as penalty to the District, forfeit up to two hundred \$200.00 for each calendar day, or portion thereof, for each worker paid less than the minimum prevailing wages for such work or craft in which such worker is employed by the Contractor or by any Subcontractor, as required in Subsection 15.1.

15.5 Payroll Records

The Contractor, each Subcontractor and each services provider subject to prevailing wage requirements shall electronically submit to the Labor Commissioner, keep and file with the District an accurate payroll record, showing the name, address, social security number, work classification, straight time and overtime hours worked each day and week, and the actual per diem wages paid each journeyman, apprentice or worker employed by him/her in connection with the public work. The said payroll records shall be available for inspection at all reasonable hours, and a copy shall be made available to the employee of his/her authorized representative, the Division of Labor Standards Enforcement, and the Division of Apprenticeship Standards. The Contractor shall comply with the Certified Payroll Record (CPR) requirements of section 1771.4 and section 1776 of the Labor Code and shall require and verify that all subcontractors of every tier and services providers comply with such CPR requirements.

Pursuant to California Labor Code section 1776 (h), the Contractor, subcontractor or services provider has 10 days in which to comply subsequent to receipt of a written notice requesting the records enumerated in subdivision (a) of section 1776. In the event that the Contractor, subcontractor or services provider fails to comply within the 10-day period, he or she shall, as a penalty to the state or political subdivision on whose behalf the Contract is made or awarded, forfeit one hundred dollars (\$100) for each calendar day, or portion thereof, for each worker, until strict compliance is effectuated. Upon the request of the Division of Apprentice Standards or the Division of Labor Standards Enforcement, these penalties shall be withheld from progress payments then due. A Contractor is not subject to a penalty assessment pursuant to this section due to the failure of a subcontractor to comply with this section.

15.6 Employment of Registered Apprentices

The provisions of sections 1777.5, 1777.6, and 1777.7 of the California Labor Code shall be applicable to the Contractor and each subcontractor involved in the construction of the work of improvement.

In the event a Contractor or subcontractor is determined by the Chief of the Division of Apprenticeship Standards to have knowingly violated section 1777.5, he or she shall forfeit as a civil penalty an amount

not exceeding one hundred dollars (\$100) for each full calendar day of noncompliance. The amount of this penalty may be reduced by the Chief if the amount of the penalty would be disproportionate to the severity of the violation.

15.7 Working Hours

- a. Eight hours' labor constitutes a legal day's work.
- b. The time of service of any worker employed upon this work is limited and restricted to 8 hours during any one calendar day, and 40 hours during any one calendar week, except as hereinafter provided in Subsection 15.7.e.
- c. The Contractor and each subcontractor shall keep an accurate record, showing the name of and actual hours worked each calendar day and each calendar week by each worker employed by him in connection with this work. The record shall be kept open at all reasonable hours to the inspection of the District and to the Division of Labor Law Enforcement of the State of California.
- d. The Contractor shall, as a penalty to the District, forfeit \$25.00 for each worker employed in the execution of this Contract by the Contractor or by any subcontractor for each calendar day during which such worker is required or permitted to work more than 8 hours in any one calendar day and 40 hours in any one calendar week in violation of these provisions.
- e. Notwithstanding the provisions of Subsection 15.7.a to 15.7.d, inclusive above, work performed by employees of the Contractor or any subcontractor, in excess of 8 hours per day, and 40 hours during any one week, shall be permitted if compensation shall be paid for all hours worked in excess of 8 hours per day at not less than 1.5 times the basic rate of pay.

15.8 Workers' Compensation

- a. In accordance with the provisions of section 3700 of the California Labor Code, and in accordance with the Longshore and Harbor Workers' Compensation Act, the Contractor shall be required to secure the payment of compensation to his/her employees.
- b. Prior to performing the work of the Contract, the Contractor shall sign and file with the District a certification in the words and phrases set forth in section 1861 of the California Labor Code.

15.9 License Qualifications of Bidder

Only bids of Contractors qualified and authorized by license to perform the work will be considered. Each bid submitted shall set forth the classification and number of the California Contractor's State License Board license held by the bidder.

15.10 Listing of Subcontractors

Each bidder, in submitting his Bid, shall complete and enclose with the bid a "Bidder's Statement of Subcontractors," which shall contain the following information with respect to each subcontractor to be used on the project:

- a. The name and the location of the place of business of each subcontractor who will perform work or labor or render service to the Contractor in or about the work in an amount in excess of one-half percent (1/2%) of the Contractor's total bid.
- b. The portion of the work which will be done by each such subcontractor.

- c. If the Bidder fails to specify a subcontractor or if a Bidder specifies more than one subcontractor for the same portion of work to be performed under the Contract in excess of one-half percent of the Bidder's total bid, the Bidder agrees that he or she is fully qualified to perform that portion himself or herself and that the Bidder shall perform that portion himself or herself.
- d. In the event that the Contractor violates any provision of Chapter 4 of Part 1 of Division 2 of the Public Contract Code of the State of California related to the use of subcontractors other than those listed in the Contractor's Bid, then and in such event, the Contractor shall have violated his Contract with the District and these Contract Documents and Specifications. If such violation occurs, the District may exercise the option, in its own discretion, of (1) canceling the Contract with the Contractor or (2) assessing the Contractor a penalty in an amount not to exceed ten percent (10%) of the amount of the subcontract involved, all as more particularly set forth in section 4110 of the Public Contract Code of the State of California.

15.11 Insertion in Subcontracts

The Contractor shall insert in all construction subcontracts the clauses set forth in this section 15, so that all of the provisions of this section 15 will be inserted in all construction subcontracts of any tier.

15.12 State Prevailing Wage Rates

Local Prevailing Rate of Per Diem Wages as established by the Director of DIR is available for review at the offices of the District.

16. SUBCONTRACTORS, MATERIAL SUPPLIERS AND SERVICES PROVIDERS

All bids shall be accompanied by a List of Subcontractors, Material Suppliers and Services Providers to be used on the work indicating the nature of work or materials to be done or supplied by each and the percentage of the total which each will perform. Services Providers shall be listed if the work being performed is subject to prevailing wage requirements. Material Suppliers shall be listed using the criteria shown in General Provision 15.10, Listing of Subcontractors.

17. BID ITEMS

Items bid shall be for the complete operating project as shown on the plans and described in the specifications and shall include all materials, labor, tools, overhead, profit and anything else necessary for a complete workmanlike job.

Payments shall be made on the basis of the bid items listed on the proposal and no additional claims for compensation will be allowed therefore.

18. INTENT OF PLANS AND SPECIFICATIONS

The intent of the plans and specifications is to prescribe the details for the construction and completion of the work which the Contractor undertakes to perform in accordance with the terms of the Contract. Where the plans or specifications describe portions of the work in general terms, but not in complete details, it is understood that only the best general practice is to prevail and that only materials and workmanship of the first quality are to be used.

19. DOCUMENT PRECEDENCE

The component Contract documents are intended to provide explanation for each other.

Any work shown on the Plans and not in the Specifications, or vice versa, is to be executed as if indicated in both. In case of a conflict in the Contract, the following order of precedence will govern interpretation of the Contract:

- a. Field instructions or other written directives
- b. Addenda
- c. Plans
- d. Specifications

20. INTERPRETATIONS AND REQUESTS FOR APPROVED EQUALS/CHANGES

Changes and clarifications of the Contract Documents and Specifications, or approved equals, shall only be made by written addendum, signed, numbered, and dated by the District. Bidders will be bound by all addenda issued, whether or not received by the Bidder; it shall be the Bidder's responsibility to make inquiry as to addenda issued.

Bidders may make appointments to discuss these specifications with the District. This, however, does not relieve the Bidder from the written, documented requests required by this section.

Requests for approved equals, clarification of specifications, and protest of specifications must be received by the District in writing, not later than seven (7) calendar days before the date of the scheduled bid date. Any request for an approved equal or protest of the specifications must be fully supported with technical data, test results, or other information as evidence that the substitute offered is equal to or better than the specifications' requirement.

The District's replies to requests will be postmarked no later than five (5) calendar days after the date of the original requests unless otherwise indicated in writing by the District.

21. WORK TO BE DONE

The work to be done consists of furnishing all labor, methods and processes, implements, tools, machinery, and materials, except as otherwise specified, which are necessary and required to construct and put in complete order for use, the work designated in the Contract, and to leave the grounds in a neat condition.

22. ALTERATIONS

The District reserves the right to increase or decrease the quantity of any item or portion of the work, or to omit portions of the work as may be deemed necessary or expedient by the District; also to make such alterations or deviations, increases or decreases, additions or omissions, in the plans and specifications, as may be determined during the progress of the work to be necessary and advisable. If the final quantity of any item of work required under the Contract varies from the Engineer's Estimate by twenty-five percent (25%) or more, compensation will be adjusted in accordance with Caltrans State Specification section 4-1.03B, "Increased or Decreased Quantities."

23. BID ITEM OVERRUN

Throughout the Contract (at a minimum, once a week), the Contractor shall be responsible to monitor placement or installation of unit price items (if any) with respect to the original estimated quantities shown in the Contract. If placement or installation indicates a possible overrun with respect to the original estimated quantities shown in the Contract, the Contractor shall immediately provide written notification to the District with revised total estimated quantities. Materials (overrun) placed by the Contractor without prior approval or consent of the District may not be paid.

24. EXTRA AND FORCE ACCOUNT WORK

New and unforeseen work will be classed as extra work when such work cannot be covered by any of the various items or combination of items for which there is a bid price.

The Contractor shall do no extra work except upon written order from the District. For such extra work the Contractor shall receive payment as previously agreed upon in writing, or he shall be paid on force account. Extra work, when ordered and accepted, shall be paid for under a written work order in accordance with the terms therein provided. Payment for extra work will be made at the unit price or lump sum previously agreed upon by the Contractor and the District, or by force account.

If the work is done on force account, the Contractor shall receive the actual cost of all materials furnished by him and equipment rental as shown by his paid vouchers, plus fifteen percent (15%); for all labor and teams that are necessary, he shall receive the current prices in the locality, which shall have been previously determined and agreed to in writing by the District and by the Contractor, plus twenty percent (20%) provided, however, that the District reserves the right to furnish such materials required as it deems expedient, and the Contractor shall have no claim for profit on the cost of such materials. The price paid for labor shall include any compensation insurance paid by the Contractor.

All extra work and force account shall be adjusted daily upon receipt sheets, prepared by the District, furnished to the Contractor and signed by both parties, which daily reports shall thereafter be considered the true record of extra work or force account work done.

25. PROGRESS PAYMENTS

The District shall, upon receipt of a Contractor invoice, cause an estimate in writing to be made by the District of the total amount of work done and the acceptable materials furnished and delivered by the Contractor on the ground, to the time of such estimate and the value thereof. The District shall retain five percent (5%) of the value of the materials and labor so estimated to have been furnished and delivered as aforesaid as part security for the fulfillment of the Contract by the Contractor, and shall pay to the Contractor, while carrying on the work, the balance not retained, as aforesaid, after deducting therefrom all previous payments and all sums to be kept or retained under the provisions of the Contract. No such estimate or payment shall be required to be made when, in the judgment of the District, the work is not proceeding in accordance with the provisions of the Contract, or when in his judgment, the total value of the work done since the last estimate amounts to less than one thousand dollars (\$1,000). Work will not be considered complete in areas where a certificate of approval from the City of Sacramento, State, or other regulatory agency is required, until said certificate is received by the District. Retained percentage shall be paid to the Contractor upon final completion and acceptance of all work and 30 days after District files notice of completion with the City of Sacramento.

26. FINAL PAYMENT

The District shall, after completion of the Contract, make a final estimate of the amount of work done thereunder, and the value of such work; and the District shall pay the entire sum so found to be due after deducting therefrom all previous payments and all amounts to be kept and all amounts to be retained under the provisions of the Contract. All prior partial estimates and payments shall be subject to correction in the final estimate and payment. The final payment shall not be due and payable until the expiration of sixty (60) days from the date of acceptance of the work by the District.

It is mutually agreed between the parties to the Contract that no certificate given or payments made under the Contract, except the certificate of final payment, shall be conclusive evidence of the performance of the Contract, either wholly or in part, against any claim of the party of the first part, and no payment shall be construed to be an acceptance of any defective work or improper materials.

The Contractor further agrees that the acceptance of the final amount due under the Contract, and the adjustment and payment for any work done in accordance with any alterations of the same, shall release the District from any and all claims or liability on account of work performed under the Contract or any alteration thereof.

27. RELEASE OF RETENTION

In accordance with the provisions of section 22300 of the Public Contract Code, the Contractor may elect to receive 100 percent of payments due under the Contract from time to time, without retention of any portion of the payment, by entering into an Escrow Agreement for Security Deposits in Lieu of Retention.

28. PUBLIC LIABILITY AND PROPERTY DAMAGE INSURANCE

The Contractor shall take out and maintain during the life of the Contract, Public Liability and Property Damage Insurance, in which the "Indemnified Parties," collectively referred to all of the following: District and its board of trustees, officers, agents and employees; and the State of California, and all of its agencies, departments, officers, agents and employees, including but not limited to the Central Valley Flood Protection Board and the Department of Water Resources and their respective officers, agents and employees, shall be named as an additional assured, which will protect the Contractor, and/or all subcontractors, Indemnified Parties, against any claims for personal injury, including accidental death as well as from the operation of the Contractor, whether such operation shall have been performed by the Contractor, and subcontractor, or by anyone employed either directly or indirectly by any of them.

The Public Liability and Property Damage Insurance shall be provided with the limits not less than the following:

1. Limit of Liability for Injury or Accidental Death:
Per Occurrence \$1,000,000
2. Limit of Liability for Property Damage:
Per Occurrence \$1,000,000

The Contractor shall furnish the District with satisfactory proof of the carrying of the required insurance by submitting certifications or policies of insurance to the District prior to commencement of work under the Contract. Any work performed prior to the submission of such certification or policies shall be considered as having been done at the Contractor's own risk and as a volunteer.

29. LAWS TO BE OBSERVED

The Contractor shall keep himself fully informed of all existing and future State and Federal laws and all municipal and City of Sacramento ordinances and regulations which in any manner affect those engaged or employed in the work, or the materials used in the work, or which in any way affect the conduct of the work, and of all such orders and decrees of bodies or tribunals having any jurisdiction or authority over the same.

30. PERMITS AND LICENSES

The Contractor shall procure all permits and licenses, pay all charges and fees, and give all notices necessary and incidental to the due and lawful prosecution of the work.

31. SAFETY PROVISIONS

The Contractor shall conform to the rules and regulations pertaining to safety established by the California Division of Industrial Safety.

32. PUBLIC CONVENIENCE AND SAFETY

The Contractor shall so conduct his operations as to offer the least possible obstruction and inconvenience to the public, and he shall have under construction no greater amount of work than he can prosecute properly with due regard to the rights of the public.

Construction operations shall be conducted in such a manner as to cause as little inconvenience as possible to abutting property owners.

Whenever the Contractor's operations create a condition hazardous to his employees or the public, he shall furnish, erect, and maintain at his expense and without cost to the District, such fences, barricades, lights, signs and other protective devices as are necessary to prevent accidents, damages, or injury to his employees or the public.

Should the Contractor appear to be neglectful or negligent in furnishing warning and protective measures as provided above, the District may direct attention to the existence of a hazard and the necessary warning and protective measures shall be furnished and installed by the Contractor at his expense. Should the District point out the inadequacy of warning and protective measures, such action on the part of the District shall not relieve the Contractor from the responsibility for public safety or abrogate his obligation to furnish and pay for these devices.

33. PRESERVATION OF PROPERTY

Trees, shrubs, and other plants that are not to be removed; and pole lines, fences, signs, markers and monuments, buildings and structures, conduits, pipelines under or above ground, sewer and waterlines, all highway facilities, and any other improvements or facilities shall be protected from injury or damage, and if ordered by the District, the Contractor shall provide and install suitable safeguards, approved by the District, to protect such objects from injury or damage. If such objects are injured or damaged by reason of the Contractor's operations, they shall be replaced or restored at the Contractor's expense. The facilities shall be replaced and restored to a condition as good as when the Contractor entered upon the work.

The fact that any underground facility is not shown upon the plans shall not relieve the Contractor of his responsibility under this section. It shall be the Contractor's responsibility to ascertain the existence of any underground improvements or facilities which may be subject to damage by reason of his operations.

Full compensation for furnishing all labor, materials, tools, equipment, and incidentals, and for doing all the work involved in protecting or repairing property as specified in this section shall be considered as included in the prices paid for the various Contract items of work and no additional compensation will be allowed therefore.

34. PROGRESS OF THE WORK AND TIME FOR COMPLETION

The Contractor shall begin work within ten (10) days after receiving the Notice to Proceed and shall diligently prosecute the same to completion before October 31, 2022.

35. TIME OF COMPLETION AND LIQUIDATED DAMAGES

It is agreed by the parties to the Contract that in case all the work called for under the Contract is not completed before or upon the expiration of the time limit as set forth in these specifications, damage will be sustained by the District, and that it is and will be impracticable to determine the actual damage which the District will sustain in the event of such delay; and it is therefore agreed that the Contractor will pay to the District the sum of Three Thousand Dollars (\$3,000.00) per day for each and every day's delay beyond the time prescribed to complete the work; and the Contractor agrees to pay such liquidated damages as herein provided, and in case the same are not paid, agrees that the District may deduct the amount thereof from any monies due or that may become due the Contractor under the Contract.

The Contractor will be granted an extension of time of completion and will not be assessed with liquidated damages or the cost of engineering and inspection during any delay in the completion of the work caused by acts of God, or of the public enemy; acts of the District; fire, floods, epidemics, quarantine restrictions, strikes, freight embargoes, or unusually severe weather; or delays of subcontractors or suppliers arising from unforeseeable causes beyond the control, and without the fault or negligence, of both the Contractor and subcontractors or suppliers, provided that the Contractor shall within two (2) days from the beginning of any such delay notify the District in writing of the causes of delay. The District shall ascertain the facts and extent of delay, and his findings thereon shall be final and conclusive.

36. TEMPORARY SUSPENSION OF WORK

The District shall have the authority to suspend the work wholly or in part, for such period as he may deem necessary, due to unsuitable weather, high tides, or to such other conditions as are considered unfavorable for the suitable prosecution of the work, or for such time as he may deem necessary, due to the failure on the part of the Contractor to carry out orders given, or to perform any provisions of the work. The Contractor shall immediately obey such order of the District and shall not resume work until ordered in writing by the District.

37. GUARANTEE

The completed project, including all work, materials, devices, and equipment shall be guaranteed by the Contractor against faulty workmanship and materials for a period of one year after final acceptance by the District. The Contractor shall be responsible for all repair and/or replacements to include all labor, materials, equipment, devices, plant and other items of work necessary.

38. SUPERINTENDENT

Prior to the commencement of work, the Contractor shall designate in writing an authorized representative who shall have the authority to represent and act for the Contractor.

Said authorized representative shall be available at all times to the District while work is actually in progress on the Contract. When work is not in progress and during periods when work is suspended, arrangements acceptable to the District shall be made for any emergency work which may be required.

Whenever the Contractor or his authorized representative is not present on any particular part of the work where it may be desired to give direction, orders will be given by the District, which shall be received and obeyed by the superintendent or foreman who may have charge of the particular work in reference to which the orders are given.

Any order given by the District, not otherwise required by the specifications to be in writing, will on request of the Contractor, be given or confirmed by the District in writing.

39. LINES AND GRADES

All distances and measurements are given and will be made in a horizontal plane. Grades are given from the top of stakes or nails, unless otherwise noted on the plans.

Three consecutive points shown on the same rate of slope must be used in common, in order to detect any variation from a straight grade, and in case such discrepancy exists, it must be reported to the District, the Contractor shall be responsible for any error in the finished work.

The Contractor shall give at least 48 hours' notice in writing when he will require the services of the District for laying out any portion of the work.

The Contractor shall preserve all benchmarks, survey monuments, stakes and points set for lines, grades, or measurements of the work in their proper places until authorized to remove them by the District. All expenses incurred in replacing stakes that have been removed without proper authority shall be paid by the Contractor.

40. INSPECTION

The District shall at all times have access to the work during construction, and shall be furnished with every reasonable facility for ascertaining full knowledge regarding the progress of the work, quality of workmanship, and character and quantity of materials used in the workplace.

Whenever the Contractor varies the period during which work is carried on each day, he shall give due notice to the District, so that proper inspection may be provided. Any work done in the absence of the District will be subject to rejection.

The inspection of the work shall not relieve the Contractor of any of his obligations to fulfill the Contract as prescribed. Defective work shall be made good, and unsuitable materials may be rejected, notwithstanding the fact that such defective work and unsuitable materials have been previously overlooked by the District and accepted or estimated for payment.

Projects financed in whole or in part with State and/or Federal funds shall be subject to inspection at all times by the agencies involved.

41. FINAL INSPECTION

Whenever the work provided and contemplated by the Contract shall have been satisfactorily completed and the final cleanup performed, the District will make the final inspection.

If the work has been satisfactorily completed and accepted, the Contractor will be notified of acceptance.

If the Engineer and/or District determine that the work is not complete, the Contractor will be notified of the deficiencies. The Contractor shall initiate procedures to correct the deficiencies noted and another final inspection shall be made before complete acceptance of the project and final payment.

The cost of all work to be performed to correct any deficiencies shall be borne by the Contractor and shall include furnishing all labor, tools, transportation, supplies, equipment, appurtenances, fuel, and power.

If additional material is required to correct the deficiency, and is agreed upon by the District, it will be paid for by the District as stipulated under General Provision No. 24, "Extra and Force Account Work".

42. DUST AND MUD CONTROL

During dry conditions, the Contractor shall keep all areas generating dust well-watered. During wet conditions, the Contractor shall keep all roadways adjacent to the project area, which are used by the public, free and clear from mud. Any surface waters entering or leaving the work area shall be intercepted and disposed of or stored to prevent interference with construction and/or damage to excavations and structures. Any damage to excavations, structures or downstream property by surface water shall be repaired as required at the expense of the Contractor. The Contractor shall not allow ponding of surface waters associated with construction. Should any fill become wet or saturated at any time during the Contract, all fill materials which, as determined by the Engineer, have become unsuitable by reason of such flooding, shall be removed and replaced with approved material at the expense of the Contractor.

43. CONTROL OF WORK

All work shall be subject to the control of the District. Contractor shall immediately cease any operation upon the request of the District. District reserves the right, upon the recommendation of the District, to cancel this Contract at any time. In the event of cancellation, Contractor shall be paid the unit price for the work performed to the date of cancellation.

44. RIGHT-OF-WAY

Coordination with private landowners for access road purposes shall be the responsibility of the Contractor. The Contractor, upon completion of all work, shall restore all access roads to project sites to the conditions existing prior to commencement of work.

45. USE OF EXPLOSIVES

Explosives shall not be used in connection with this Contract.

46. NOTICE OF ENTRANCE

If any portions of the work specified herein are to be installed in rights-of-way passing through privately owned land, it is of utmost importance that before entering any private property, the Contractor shall give the tenant and Engineer a minimum of forty-eight (48) hours' notice.

47. MAINTENANCE OF TRAFFIC

Throughout the performance of the work or in connection with this contract, the Contractor shall maintain suitable and safe ingress and egress from public and private ways, and private dwellings and businesses, in such manner as shall give as little inconvenience as possible to the traveling public and to adjoining property owners.

48. PROTECTION OF BRIDGES

The Contractor shall be responsible for any damage he may cause to bridges, culverts, and road structures. He shall determine in advance the allowable safe load for each structure and, if necessary, provide special shoring and support at his expense.

49. RESPONSIBILITY FOR DAMAGE

The Contractor shall assume the defense of, and indemnify and hold harmless the District and each and every employee and agent, thereof from all suits, actions, damages, or claims of every name and description to which the District may be subjected or put by reason of injury to persons or property in the execution of the work or resulting from negligence or carelessness on the part of the Contractor, his employees or agents, in the delivery of materials and supplies, or by or on account of any act or omission of the Contractor, his employees or agents, including any failure to fulfill the terms of all laws and regulations which apply to this contract; and the District shall have the right to estimate the amount of such damage and to cause the Contractor to pay the same; and the amount so paid for such damage shall be deducted from the money due or to become due the Contractor under this contract, as may be considered necessary by the District, and shall be retained by the District until such suits or claims for damages shall have been settled or otherwise disposed of, and satisfactory evidence to that effect furnished to the District.

50. CARE OF GROUNDWATER

If groundwater seepage is encountered, the Contractor shall satisfactorily control the seepage into and along the bottoms of the excavations to prevent damage to property. The Contractor will notify the District if groundwater is encountered.

51. PROTECTION OF CONTRACTOR'S WORK AND PROPERTY

The Contractor shall protect his work, supplies, and materials from damage due to the nature of the work, the action of the elements, trespassers, or any cause whatsoever under his control, until the completion and acceptance of the work.

Neither the District nor the any of the District's agents assume any responsibility for collecting indemnity from any person(s) causing damage to the work of the Contractor.

QUALITY CONTROL

1. GENERAL

This section covers the quality control inspection, sampling, and testing of all supplies, services, and/or workmanship required to be performed under the contract. The Contractor shall perform all quality control inspection and/or testing required by this contract. The Contractor shall inspect and test all materials and operations, including but not limited to those items listed at the end of this section under number 5, Inspection and Tests.

2. QUALITY CONTROL SYSTEM

The Contractor shall provide and maintain an effective quality control program or Contractor inspection system which will assure that all supplies and services required under the contract conform to contract requirements whether constructed or processed by the Contractor or procured from subcontractors or vendors.

2.1 Inspection and Testing

The Contractor's inspection system shall require personnel of his organization to perform or cause to be performed inspections and testing of the scope and character necessary to achieve the quality of construction required by the contract plans and specifications.

2.2 Inadequacies

If recurring deficiencies indicate that the quality control system is not adequate, corrective action shall be taken as directed and progress payments will be withheld until such corrective action has been completed.

3. DAILY RECORDS

The Contractor shall maintain a daily record of all inspections and tests performed for each shift of Contractor or subcontractor operations in an appropriate format. These records shall not only identify the project but shall include data on weather conditions, the Contractor and/or subcontractors working and their respective areas of responsibility, and a listing of construction equipment, other than hand tools, at the job site and whether or not used on the report day. In addition, these records shall provide factual evidence that continual quality control inspections and tests have been performed. These records shall include a statement that all supplies and materials incorporated in the work are in full compliance with the terms of the contract. The Contractor shall maintain a current record of all inspections and shall furnish the District, on a daily basis, a legible copy of all inspection records for his permanent retention. The daily records of inspections shall cover all work placement subsequent to the previous report and shall be verified by the Contractor's designated representative. A sample of a typical Contractor Quality Control Report form is included. All contractually specified tests or portions thereof shall be recorded and attached to the daily report of the date upon which the test occurs.

4. PAYMENT

No separate payment will be made for the Contractor's quality control inspection performed under this contract, and all costs in connection therewith will be considered a subsidiary obligation of the Contractor.

5. INSPECTION AND TESTS

Refer to Technical Provisions, under Sections 5.2.6, 6.1.6, 6.1.7, 6.3.4.

6. SAMPLE OF TYPICAL DAILY QUALITY CONTROL REPORT

CONTRACTOR'S NAME _____

(Address)

DAILY QUALITY CONTROL REPORT

Date: _____ Report No.: _____

Contract No.: _____

Name and Location of Project: _____

WEATHER: Clear P. Cloudy Cloudy Temperature _____

Rainfall: _____ Inches Min. _____ Max. _____

1. WORK PERFORMED TODAY: (Indicate location and description of work performed. Refer to work performed by prime and/or subcontractors.)

EQUIPMENT DATA: (Indicate items of construction equipment, other than hand tools, at the job site and whether or not used.)

ENVIRONMENTAL PROTECTION

1. GENERAL

The work covered by this section consists of performing all work required for the prevention of environmental pollution during and as the result of construction operations under this contract. For the purpose of this specification, environmental pollution is defined as the presence of chemical, physical, or biological elements or agents, which adversely affect human health or welfare; unfavorably alter ecological balances of importance to human life; affect other species of importance to man; or degrade the utility of the environment for aesthetic and recreational purposes. The control of environmental pollution requires consideration of air, water, and land; and it involves noise, solid waste management, and management of radiant energy and radioactive materials, as well as other pollutants.

2. APPLICABLE REGULATIONS

In order to prevent, and to provide for abatement and control of, any environmental pollution arising from the construction activities of the Contractor and his subcontractors in the performance of this contract, they shall comply with all applicable Federal, State and local laws, and regulations concerning environmental pollution control and abatement.

3. SUBCONTRACTORS

Compliance with the provisions of this section by subcontractors will be the responsibility of the Contractor.

4. COORDINATION AND SURVEILLANCE

During the work, the Contractor shall oversee all activities, including those of subcontractors, to assure compliance with the intent and details of the specifications. All equipment and materials for environmental protection shall be inspected periodically to assure that they are in proper order and have not deteriorated.

5. ENVIRONMENTAL PROTECTION

During construction, the Contractor shall assure that all personnel working on the job are familiar with the environmental protection provisions of the contract specifications. Operators of equipment used for excavation and placement of stone fill, embankment, and bank protection material shall be specifically informed of water quality standards and instructed in methods for conducting the operation to minimize effects on water quality.

5.1 Completion

All restoration, cleanup, and other work required to leave the site in an acceptable condition as determined by the District shall be complete prior to clearing any new site.

6. PROTECTION OF LAND RESOURCES

6.1 General

It is intended that the land resources within the project boundaries and outside the limits of permanent work performed under this contract be preserved in their present condition or be restored to a condition after completion of construction that will appear to be natural and not detract from the appearance of

the project. Insofar as possible, the Contractor shall confine his construction activities to areas defined by the plans and specifications, and borrow areas indicated on the plans.

6.2 Prevention of Landscape Defacement

Except in areas marked on the plans to be cleared, the Contractor shall not deface, injure, or destroy trees or shrubs, nor remove or cut them without special authority. No ropes, cables, or guys shall be fastened to or attached to any existing nearby trees for anchorages. Where such special emergency use is permitted, the Contractor shall first adequately wrap the trunk with a sufficient thickness of burlap or rags over which softwood cleats shall be tied before any rope, cable, or wire is placed. The Contractor shall in any event be responsible for any damage resulting from such use. Where, in the opinion of the District, trees may possibly be defaced, bruised, injured, or otherwise damaged by the Contractor's equipment or by his blasting, dumping, or other operations, he may direct the Contractor to protect adequately such trees by placing boards, planks, or poles around them. When earthwork operations are liable to cause rock to roll or otherwise be displaced into uncleared areas, the Contractor shall construct barriers to protect the trees. Rocks that are displaced into uncleared areas shall be removed.

6.3 Restoration of Landscape Damage

Any trees or other landscape feature scarred or damaged by the Contractor's equipment or operations shall be restored as nearly as possible to its original condition at the Contractor's expense.

6.4 Post-Construction Cleanup or Obliteration

The Contractor shall obliterate all signs of temporary construction facilities such as haul roads, work areas, structures, foundations of temporary structures, stockpiles of excess or waste materials, or any other vestiges of construction as directed.

7. RECORDING AND PRESERVING HISTORICAL AND ARCHEOLOGICAL FINDS

All items having any apparent historical or archeological interest, which are discovered in the course of any construction activities shall be carefully preserved. The Contractor shall leave the archeological find undisturbed and shall immediately report the find to the District so that the proper authorities may be notified.

8. PROTECTION OF WATER RESOURCES

8.1 General

All work under this contract shall be performed in such a manner that objectionable conditions will not be created in streams through or adjacent to the project areas.

8.2 Spillages

At all times of the year, special measures shall be taken to prevent chemicals, fuels, oils, greases, bituminous materials, waste washings, herbicides and insecticides, and cement and surface drainage from entering public waters.

8.3 Disposal

Disposal of any materials, wastes, effluents, trash, garbage, oil, grease, chemicals, etc., in areas adjacent to streams shall not be allowed unless with the approval of an authorized representative of the District.

Water from the material set on the bank to dry shall not be allowed to flow directly back into the river and shall be returned to the river as directed. If any waste material is dumped in unauthorized areas, the Contractor shall remove the material and restore the area to the condition of the adjacent undisturbed area. If necessary, contaminated ground shall be excavated, disposed of, and replaced with suitable fill material, then compacted and finished with topsoil all at the expense of the Contractor. All logs, brush, slash and other debris shall be mulched in place.

9. PROTECTION OF FISH AND WILDLIFE

The Contractor shall at all times perform all work and take such steps required to prevent interference or disturbance to fish and wildlife. The Contractor will not be permitted to alter water flows or otherwise disturb native habitat adjacent to the project area that is critical to fish or wildlife. Fouling or polluting of water will not be permitted.

10. PAYMENT

No separate payment will be made for the work covered under this section and all costs in connection therewith will be considered a subsidiary obligation of the Contractor.

11. QUALITY CONTROL

Attention is directed to the previous section, Quality Control, which requires the Contractor to perform quality control inspection, testing, and reporting.

TECHNICAL PROVISIONS

1. GENERAL

1.1 Scope of Work

The project consists of removal and reconstruction of a portion of an existing floodwall along the waterside edge of the levee crown of the Arcade Creek North Levee. The project work will be performed in two phases: The first phase will involve saw-cutting to demolish a 30-foot-long panel in an existing reinforced concrete floodwall that measures 3'-6" high by 8" thick, and transporting and disposing of demolition waste offsite. The removed portion of the floodwall will remain open to allow access to conduct erosion repairs along the north bank of Arcade Creek (by others). The second phase will involve reconstructing the demolished wall panel to preconstruction lines and grades using reinforced concrete. Reconstruction will include drilling and setting dowels to anchor the reconstructed wall panel back into existing concrete on all sides. The second phase of work cannot begin until access to erosion sites no longer require the opening in the floodwall.

The scope of work is defined by the Technical Provisions included herein, the Plans included in Attachment B, and requirements presented in this Contract Document.

The Contractor is required to subcontract with a certified ready-mix plant for the supply and delivery of concrete and with a certified materials testing laboratory to sample and test concrete at the point of placement as required in the Specifications. Site batching of concrete is not permitted.

The north levee of Arcade Creek is part of a Federal flood control project. The American River Flood Control District (District) is the responsible agency for operating and maintaining the levee system. The description of the Work to be performed that is provided herein is intended to be a general overview and does not include all the work actually required under the Contract.

1.2 Type of Contract

This Contract consists of Lump Sum and Unit Rate Bid Schedule Items.

1.3 Project Location

As shown on the plans, the Project is located within a residential area within the City of Sacramento, California, along a portion of the north flood control levee of Arcade Creek between Rio Linda Boulevard and Marysville Boulevard.

1.4 Work to be Performed by the Contractor

- a. Pre-construction site visit and meeting with the District.
- b. Mobilization and demobilization.
- c. Survey sufficient to document the alignment and elevations of the existing wall panel to be removed to support reconstruction.
- d. Excavation as required to expose the base of the wall panel and stockpiling the material for reuse.
- e. Saw cutting and demolition of the existing wall panel, including removal and legal disposal of demolition waste offsite
- f. Providing and installing all required dowels for panel reconstruction, including drilling and epoxy grouting.

- g. Reconstructing the wall panel to pre-existing conditions, including providing and installing all required reinforcement, formwork and bracing, concrete, joint filler, caulking, and other miscellaneous materials.
- h. Backfilling any excavation required to reconstruct the wall panel.

1.5 Water Supply and Sanitation during Construction

The Contractor shall be responsible for providing all water required to construct the work, including payment of all fees. Pumping from Arcade Creek will not be permitted. The Contractor shall be responsible for providing drinking water for all personnel connected with the work. The Contractor shall provide and maintain within the construction area field-type sanitary facilities approved by the District for its personnel.

1.6 Site Access

The site may be accessed from Rio Linda Boulevard traveling east along the north levee crown road, or by using the existing levee access road from Rivera Drive, which is shown on the plans. Access through Hagginwood Park from Marysville Boulevard shall not be permitted. Contractor employees shall park vehicles, in locations approved in advance by the District. Modifications to the levee crown or the access road shall not be permitted unless approved in advance by the District.

1.7 Contractor's Use of the Premises

In addition to requirements presented elsewhere on the Plans and in the Specifications, the Contractor shall adhere to the following requirements:

- a. The Contractor shall have charge and care of, and bear the risk of damage to, the Project until its completion and final acceptance.
- b. The Contractor shall not create or permit the continued existence of any nuisance in or about the work site.
- c. The Contractor shall protect and not disturb existing facilities, or access thereto, which are not in the work area or are in the work area and can be avoided.
- d. The Owner will provide the lands, easements, and rights-of-way, or other right-to-enter and work on lands shown on the plans. Nothing herein contained and nothing marked on the plans, shall be interpreted as giving the Contractor exclusive occupancy of the lands, easements, or rights-of-way provided by the District.
- e. The Contractor shall be responsible for restoring, at its own expense, all disturbed storage and work areas to a condition similar to those existing prior to construction, except where other surfacing or treatment is required by the Plans or Specifications.
- f. The general work area is shown on the Plans. The Owner will designate a laydown area for Contractor's use in the vicinity of the work. Contractor shall be responsible for the safety and security of its material and equipment on site.

1.8 Underground Utilities

The Work requires only limited shallow excavations and there are no known buried utilities in the area. Contractor shall, however, contact USA to verify.

1.9 Property Damage

In the event damage occurs to any property adjacent to the Work, or to any part of the Work being performed due to Contractor's operations or negligence of the Contractor, the Contractor will be held responsible for damages and liable for repair costs.

1.10 Permits

The Contractor is responsible to obtain any encroachment permits for any work that might be needed within the public right-of-way.

1.11 Project Meetings

A brief site kickoff meeting with the Contractor will be held at the start of each phase of work to review the work approach and schedule. If deemed necessary, the District may request additional meetings with the Contractor.

1.12 Schedule

Within 5 days of the issuance of the notice to proceed, the Contractor shall provide the District a schedule showing when key activities of the work will be executed for each phase. Microsoft Excel, Microsoft Project, or other scheduling program may be used.

1.13 Superintendence

The Contractor shall keep on the Work, throughout its progress, a competent superintendent who shall have complete authority to represent and act for the Contractor. Such superintendent shall be capable of reading and understanding the Contract, and shall receive and follow any instruction given by the District. Whenever the Contractor or the Contractor's superintendent is not present on a particular part of the Work where it may be desired to give direction, orders will be given by the District and shall be received and obeyed by the foreman or other representative who may have charge of the particular work in reference to which the orders are given, or the District may stop the work until the Contractor or the Contractor's superintendent arrives.

1.14 Site Maintenance

Throughout all phases of construction, and until final acceptance of the project, the Contractor shall keep the premises occupied in a clean and orderly condition, disposing of refuse in a manner satisfactory to the District.

2. SUBMITTALS

Submittals shall be provided when required in the Contract Documents and Technical Provisions. Submittals shall include descriptions of work, drawings and sketches, certifications, testing results, required forms, vendor information, construction procedures and any other information required to clearly define means and methods. The Contractor and the District shall agree on the form to be used for submittals following notice to proceed. The cost to prepare submittals and resubmittals will not be paid separately, and these costs are assumed to be included in the Contractor's bid schedule bid prices for the work.

Provide submittals to the District in a timely fashion to allow a minimum of two week for District review and approval prior to schedule start of the covered work activity.

The District will return submittals marked as follows:

1. Rejected. The District may reject a submittal that is considered incomplete.
2. Approved. Work may proceed.
3. Approved as Noted. Work may proceed, but District comments must be implemented in the work.
4. Revise and Resubmit. Work may not begin. Revise and resubmit the submittal to address District comments.

Copies of approved submittals shall be on site when work is in progress. Modification to work covered by an approved submittal shall not be made without prior approval of the District, which may require a resubmittal.

Refer to the Technical Specifications in Appendix B for required technical submittals. Additional submittals may be included in this Section

The following items shall be submitted within 5 days of the issuance of the notice to proceed:

- a. Safety Plan
- b. Traffic Control Plan
- c. Schedule of Work.

Refer to Technical Provisions, Sections 5.2.6, 6.1.6, 6.1.7, and 6.3.4 for other project submittals.

3. PUBLIC SAFETY

3.1 Public Safety

All equipment shall have all required safety features installed to prevent and minimize errant debris from impacting the travelled bike paths and roadways. All operators and laborers will be trained and approved in the proper techniques for working along public right-of-ways, as well as along private property and residences. The District, Local representatives, and City of Sacramento has the right to request stoppage of components of work if project activities are impacting the public safety.

3.2 Transient Population

A transient population is present in the Project area. If present in the work area, the District will be responsible for relocations prior to the start of construction. If people enter the work area and will not leave when asked, or if other issues develop during construction, the Contractor shall notify the District and the District will take appropriate action, including notifying appropriate agencies.

4. DEMOLITION AND DESTRUCTION

4.1 General

4.1.1 Work

This Section covers the demolition and removal of the existing flood wall panel as shown on the Plans. Provide all labor, equipment, cutting blades, water supply, and other materials required to complete the work.

4.1.2 General Requirements

The Contractor shall not begin demolition until authorization is received from the District. Remove rubble from the Project site daily and do not allow accumulations. Materials that cannot be removed daily shall be stored in approved stockpile areas.

4.1.3 Dust and Debris Control

Prevent the spread of dust and debris to adjacent properties and avoid the creation of a nuisance or hazard in the surrounding area.

4.1.4 Protection

4.1.4.1 Traffic Control Signs

Where pedestrian and driver safety is endangered in the area of removal Work, use pedestrian and traffic barricades.

4.1.4.2 Submittals

See Technical Provisions, Section 6.1.6, SD-01 Preconstruction Submittals.

4.1.4.3 Demolition Plan

Submit demolition plan, including saw cutting procedures, for District approval prior to beginning the work.

4.2 Products - Not Applicable

4.3 Execution

4.3.1 Saw Cutting

4.3.1.1 Excavation

Excavate the minimum required along the waterside and landside of the wall to provide clearance for saw cutting. Stockpile excavated material for reuse.

4.3.1.2 Cutting Waste

Collect wastewater and cuttings for off-site disposal. Describe collection and disposal method in the Demolition Plan.

4.3.1.3 Saw Cutting

Saw cut the existing wall, including reinforcement, along straight lines perpendicular to the face as shown on the plans. Avoid existing vertical construction joints and preserve existing waterstop. If through cutting

the wall is not possible, Contractor may make aligned cuts from both sides and describe the proposed procedure in the Demolition Plan.

4.3.1.4 Waste Removal

Break up the demolished concrete and cut reinforcement as necessary. Load, haul, and legally dispose of broken concrete and reinforcement off site.

4.4 Measurement and Payment

Demolition will not be measured for payment. Demolition will be paid at the bid schedule bid item for Demolish Existing Flood Wall Panel.

5. CONCRETE REINFORCING

5.1 GENERAL

5.1.1 References

The publications listed below form a part of this specification to the extent referenced. The publications are referred to within the text by the basic designation only.

AMERICAN CONCRETE INSTITUTE INTERNATIONAL (ACI)

ACI 117	(2010; Errata 2011) Specifications for Tolerances for Concrete Construction and Materials and Commentary
ACI 318	(2014; Errata 2014) Building Code Requirements for Structural Concrete and Commentary
ACI SP-66	(2004) ACI Detailing Manual

ASTM INTERNATIONAL (ASTM)

ASTM A370	(2014) Standard Test Methods and Definitions for Mechanical Testing of Steel Products
ASTM A615/A615M	(2014) Standard Specification for Deformed and Plain Carbon-Steel Bars for Concrete Reinforcement

CONCRETE REINFORCING STEEL INSTITUTE (CRSI)

CRSI 10MSP	(2009; 28th Ed) Manual of Standard Practice
------------	---

5.1.2 Submittals

District review is required for all submittals. Submit the following:

SD-02 Shop Drawings

Reinforcement; G

SD-07 Certificates

Reinforcing Steel

5.1.3 Delivery, Storage, And Handling

Store reinforcement and accessories off the ground on platforms, skids, or other supports.

5.2 PRODUCTS

5.2.1 Reinforcing Steel

Reinforcing steel shall be deformed bars conforming to ASTM A615/A615M, Grade 60. Sizes shall be as indicated on the Plans. Epoxy-coated reinforcing steel shall not be used.

Submit certified copies of mill reports attesting that the reinforcing steel furnished contains no less than 25 percent recycled scrap steel and meets the requirements specified herein, prior to the installation of reinforcing steel.

5.2.1.1 Mechanical Butt-Splices

Mechanical butt-splices shall not be used.

5.2.2 Dowels

Dowels shall be deformed bars conforming to the requirements of Paragraph 2.1, unless otherwise indicated on the Plans

5.2.3 Wire Ties

Use wire ties that are 16 gauge or heavier black annealed steel wire.

5.2.4 Supports

Design bar supports for formed surfaces in accordance with CRSI 10MSP and fabricate of steel or precast concrete blocks. Provide precast concrete blocks with wire ties and not less than 4 inches square when supporting reinforcement on ground. Precast concrete block must have compressive strength equal to that of the surrounding concrete. Coat steel supports for coated or galvanized bars with electrically compatible material for a distance of at least 2 inches beyond the point of contact with the bar.

Where concrete formed surfaces will be exposed to weather or where surfaces are to be painted, use galvanized, plastic protected, or stainless steel supports within 1/2 inch of concrete surface. Concrete supports used in concrete exposed to view must have the same color and texture as the finish surface. For slabs on grade and topping slabs on steel deck, supports use precast concrete blocks, plastic coated steel fabricated with bearing plates, or specifically designed wire-fabric supports fabricated of plastic.

Provide bar supports complying with the requirements of ACI SP-66.

5.2.5 Epoxy Adhesive

Epoxy adhesive for installing dowels in drilled holes shall be Simpson Set-HP, or acceptable equal.

5.2.6 Tests, Inspections, And Verifications

Perform material tests, specified and required by applicable standards, by an approved laboratory and certified to demonstrate that the materials are in conformance with the specifications. Perform and

certify tests, inspections, and verifications and certify. Submit certified tests reports of reinforcement steel showing that the steel complies with the applicable specifications for each steel shipment and identified with specific lots prior to placement. Submit three copies of the heat analyses for each lot of steel furnished certifying that the steel conforms to the heat analyses.

5.2.6.1 Reinforcement Steel Tests

Perform mechanical testing of steel in accordance with ASTM A370 except as otherwise specified or required by the material specifications. Perform tension tests on full cross-section specimens using a gage length that spans the extremities of specimens with welds or sleeves included. From chemical analyses of steel heats report the percentages of carbon, phosphorous, manganese, sulphur, and silicon present in the steel.

5.3 EXECUTION

5.3.1 Reinforcement

Fabricate and place reinforcement steel and accessories as specified, as indicated, and as shown on approved shop drawings. Fabrication and placement details of steel and accessories not specified or shown must be in accordance with ACI SP-66 and ACI 318. Cold bend reinforcement unless otherwise authorized. Bending may be accomplished in the field or at the mill. Do not bend bars after embedment in concrete. Place safety caps on all exposed ends of vertical concrete reinforcement bars that pose a danger to life safety. Face wire tie ends away from the forms. Submit detail drawings showing reinforcing steel placement, schedules, sizes, grades, and splicing and bending details. Show support details including types, sizes, and spacing.

5.3.1.1 Placement

Reinforcement must be free from loose rust and scale, dirt, oil, or other deleterious coating that could reduce bond with the concrete. Place reinforcement in accordance with ACI 318 at locations indicated plus or minus one bar diameter. Do not continue reinforcement through expansion joints and place as indicated through construction or contraction joints. Cover with concrete coverage as indicated or as required by ACI 318. If bars are moved more than one bar diameter to avoid interference with other reinforcement, conduits or embedded items, the resulting arrangement of bars, including additional bars required to meet structural requirements, requires approval before concrete is placed.

5.3.1.2 Placing Tolerances

Conform bar spacing and concrete cover to ACI 117.

5.3.1.3 Splicing

Conform splices of reinforcement to ACI 318 and make only as required or indicated. Bars may be spliced at alternate or additional locations at no additional cost to the District subject to approval. Splicing must be by lapping.

a. Lap Splices

Place lapped bars in contact and securely tied or spaced transversely apart to permit the embedment of the entire surface of each bar in concrete. Do not space lapped bars farther apart than 1/5 the required length of lap or 6 inches.

5.3.2 Dowels

Install dowels as shown on the Plans. Hole drilling, cleaning, and installation of epoxy and reinforcing bar dowels in anchorage holes shall be in accordance with adhesive manufacturer's recommendations.

5.4 MEASUREMENT AND PAYMENT

5.4.1 Measurement

Reinforcement will not be measured for payment.

5.4.2 Payment

Supply and fabrication of reinforcement, including dowels, will be paid at the bid schedule bid item Provide Reinforcement and Dowels.

6. CAST-IN-PLACE CONCRETE

6.1 General

The Work consists of furnishing all materials, performing all labor, and providing all equipment to remove and replace a section of flood wall as shown on the Plans and required by the Specifications.

6.1.1 Concrete Supplier

Subcontract with a certified ready-mix concrete supplier for supply and delivery of concrete.

6.1.2 Materials Testing Services

Subcontract with an accredited materials testing laboratory for sampling and testing of ready-mix concrete.

6.1.3 Lump Sum Work

The cost to reconstruct the flood wall panel will be paid as two lump sum items, Install Dowels and Vertical Bars, and Reconstruct Flood Wall. The lump sums shall be assumed by the District to cover all labor, material, equipment, fuel, and any other related cost required to form, place reinforcement, and supply and place concrete to provide the finished cast-in-place product.

6.1.4 References

The publications listed below form a part of this specification to the extent referenced. The publications are referred to within the text by the basic designation only.

AMERICAN CONCRETE INSTITUTE (ACI)

ACI 301	(2010; Errata 2011) Specifications for Structural Concrete
ACI 304.2R	(1996; R 2008) Placing Concrete by Pumping Methods
ACI 304R	(2000; R 2009) Guide for Measuring, Mixing, Transporting, and Placing Concrete
ACI 305.1	(2014) Specification for Hot Weather Concreting

- ACI 308.1 (2011) Specification for Curing Concrete
- ACI 309R (2005) Guide for Consolidation of Concrete
- ACI 347R (2014; Errata 1 2017) Guide to Formwork for Concrete

ASTM INTERNATIONAL (ASTM)

- ASTM C94/C94M (2021b) Standard Specification for Ready-Mixed Concrete
- ASTM C1064/C1064M (2011) Standard Test Method for Temperature of Freshly Mixed Hydraulic-Cement Concrete
- ASTM C1077 (2016) Standard Practice for Laboratories Testing Concrete and Concrete Aggregates for Use in Construction and Criteria for Laboratory Evaluation
- ASTM C1260 (2014) Standard Test Method for Potential Alkali Reactivity of Aggregates (Mortar-Bar Method)
- ASTM C143/C143M (2012) Standard Test Method for Slump of Hydraulic-Cement Concrete
- ASTM C231/C231M (2014) Standard Test Method for Air Content of Freshly Mixed Concrete by the Pressure Method
- ASTM C31/C31M (2021a) Standard Practice for Making and Curing Concrete Test Specimens in the Field
- ASTM C39/C39M (2014a) Standard Test Method for Compressive Strength of Cylindrical Concrete Specimens
- ASTM C78/C78M (2012; E 2013) Standard Test Method for Flexural Strength of Concrete (Using Simple Beam with Third-Point Loading)
- ASTM C94/C94M (2016) Standard Specification for Ready-Mixed Concrete
- ASTM D1752 (2018) Standard Specification for Preformed Sponge Rubber, Cork and Recycled PVC Expansion Joint Fillers for Concrete Paving and Structural Construction

NATIONAL READY MIXED CONCRETE ASSOCIATION (NRMCA)

- NRMCA QC 3 (2011) Quality Control Manual: Section 3, Plant Certifications Checklist: Certification of Ready Mixed Concrete Production Facilities

U.S. ARMY CORPS OF ENGINEERS (USACE)

- COE CRD-C 104 (1980) Method of Calculation of the Fineness Modulus of Aggregate

6.1.5 Submittals

District review is required for all submittals as follows:

SD-01 Preconstruction Submittals

Mix Design
Quality Control System

SD-03 Product Data

Premolded Expansion Joint Filler
Epoxy Adhesive
Form Coating Information

SD-05 Design Data

Mixture Proportions; G
Formwork Design

SD-06 Test Reports

Air Content Slump
Concrete Compressive Strength; G
Temperature Reading

SD-07 Certificates

Laboratory Accreditation; G
Ready-Mix Concrete Plant Certification

6.1.6 Quality Control

6.1.6.1 *Quality Control System*

Submit a description of Contractor's Quality Control System required in the QUALITY CONTROL Section of the CONTRACT DOCUMENTS AND SPECIFICATIONS. Include the names of the superintendent and designated independent quality control person, including their experience on concrete construction projects of equal or greater complexity. Provide a minimum of two references on projects completed in the last five years for the superintendent and independent quality control person.

6.1.6.2 *Laboratory Accreditation*

Submit the name and address of the materials testing laboratory that will sample and test concrete and provide proof of laboratory accreditation in accordance with ASTM C1077, including ASTM C78/C78M and ASTM C1260. The accreditation must be current and must include the required test methods, as specified.

6.1.6.3 *Ready-Mix Plant Certification*

Ready-mix plant equipment and facilities must be certified in accordance with NRMCA QC 3. Submit Ready-Mix Concrete Plant Certification.

6.1.6.4 District Assurance Inspection and Testing

Day-to-day inspection and testing is the responsibility of the Contractor Quality Control (CQC) staff. However, representatives of the District can and will inspect construction as considered appropriate and will monitor operations of the CQC staff. District inspection or testing will not relieve any CQC responsibilities.

6.2 PRODUCTS

6.2.1 Formwork

Design and engineer the formwork as well as its construction in accordance with ACI 301 Section 2 and 5 and ACI 347R. Fabricate of wood, steel, or other approved material. Submit formwork design prior to the first concrete placement.

Provide form coatings in accordance with ACI 301. Submit form coating information

6.2.2 Curing Materials

Provide curing materials in accordance with ACI 301, Section 5.

6.2.3 Ready-Mix Concrete

6.2.3.1 Concrete

Batch, mix, and transport normal weight, ready-mixed concrete in accordance with ASTM C94/C94M, Option A. Submit Mix Design for approval, including mix proportions, coarse and fine aggregate grading, cement content (Type I or Type II), admixtures, proof of mixture strength, and proof of material quality for all components. Approved mix design shall not be changed without prior approval of a revised mix design.

6.2.3.2 Maximum Nominal Aggregate Size

Maximum nominal aggregate size of 3/4".

6.2.3.3 Required Strength

Minimum compressive strength of 4,000 psi at 28-days based on tests on standard specimens cured under standard laboratory conditions for moist curing in accordance with ASTM C31/C31M.

6.2.3.4 Slump

Slump of 4 inches (plus or minus 1 inch) measured at point of delivery.

6.2.3.5 Air Content

Total air content of 4.5 percent.

6.2.3.6 Other Components

Concrete mix should include water reducing and air entrainment agents as needed. Class C fly ash may also be included in the mix design.

6.2.3.7 Concrete Temperature

The temperature of the concrete as delivered must not exceed 90 degrees F. When the ambient temperature during placing is 40 degrees F or less, or is expected to be at any time within six hours after placing, the temperature of the concrete as delivered must be between 55- and 75-degrees F.

6.2.4 Joint Materials

6.2.4.1 Waterstops

If required waterstop shall be extruded polyvinyl chloride, dumbbell shape conforming to CRD-C-572.

6.2.4.2 Expansion Joint filler

Expansion joint filler strips, premolded of sponge rubber conforming to ASTM D1752, Type I, or acceptable equal. Submit manufacturer's data for premolded expansion joint filler

6.2.4.3 Epoxy Adhesive

Epoxy Adhesive shall be Simpson SET-HP, or acceptable equal. Submit manufacturer's data for epoxy adhesive, including requirements for dowel hole drilling, hole cleaning, epoxy adhesive injection, and set time.

6.3 Execution

6.3.1 Installing Epoxy Anchored Dowels and Reinforcement Bars

Drill and install epoxy anchored dowels and reinforcement bars as required by the Plans. Hole drilling and cleaning, and installation of the epoxy adhesive shall be in accordance with manufacturer's requirements.

6.3.2 Preparation For Placing Concrete

Before commencing concrete placement, perform the following: Clean surfaces to receive concrete, free from frost, ice, mud, and water. Unless otherwise specified, place, clean, coat, and support forms in accordance with ACI 304R. Place, clean, tie, and support reinforcing steel. Equipment for consolidating concrete is at the placing site and in proper working order. Equipment and material for curing and for protecting concrete from weather or mechanical damage is at the placing site, in proper working condition and in sufficient amount for the entire placement. When hot, windy conditions during concreting appear probable, ensure equipment and material is at the placing site to provide windbreaks, shading, fogging, or other action to prevent plastic shrinkage cracking or other damaging drying of the concrete. Unless otherwise specified, cure concrete in accordance with ACI 308.1.

6.3.2.1 Preparation of Existing Concrete

Abrade concrete surfaces to which other concrete is to be bonded in an approved manner that exposes sound aggregate uniformly without damaging the concrete. Remove laitance and loose particles. Thoroughly wash surfaces, leaving them moist but without free water when concrete is placed.

Dispose of wastewater employed in cutting, washing, and rinsing of concrete surfaces in a manner that the wastewater does not stain, discolor, or affect exposed surfaces of the structures, or damage the environment of the Project area. The method of disposal is subject to approval.

6.3.3 Placing Concrete

Discharge mixed concrete within 1.5 hours or before the mixer drum has revolved 300 revolutions, whichever comes first after the introduction of the mixing water to the cement and aggregates. When the concrete temperature exceeds 85 degrees F, reduce the time to 45 minutes. Place concrete within 15 minutes after it has been discharged from the transporting unit. Handle concrete from mixer or transporting unit to forms in a continuous manner until the approved unit of operation is completed. Provide adequate scaffolding, ramps, and walkways so that personnel and equipment are not supported by in-place reinforcement.

Placing will not be permitted when the sun, heat, wind, or limitations of facilities prevent proper consolidation, finishing, and curing. Provide sufficient placing capacity so that concrete can be kept free of cold joints.

6.3.3.1 *Depositing Concrete*

Deposit concrete in accordance with ACI 301 Section 5 and ACI 304.2R.

6.3.3.2 *Consolidation*

Immediately after placing, consolidate each layer of concrete in accordance with ACI 301 Section 5 and ACI 309R.

6.3.3.3 *Hot Weather Requirements*

When job-site conditions are present or anticipated that accelerate the rate of moisture loss or rate of cement hydration of freshly mixed concrete, including an ambient temperature of 80 degrees F or higher, and an evaporation rate that exceeds 0.2 lb/ft²/h, conform concrete work to all requirements of ACI 305.1.

6.3.3.4 *Waterstops*

Install waterstops in conformance with the locations and details indicated using materials and procedures specified.

6.3.3.5 *Dowels and Tie Bars*

Take care during placing adjacent to and around dowels and tie bars to ensure there is no displacement of the dowel or tie bar and that the concrete completely embeds the dowel or tie bar and is thoroughly consolidated.

6.3.4 Testing And Inspection for Contractor Quality Control

Perform the inspection and tests described below and, based upon the results of these inspections and tests, take the action required.

- a. When, in the opinion of the District, the concreting operation is out of control, cease concrete placement and correct the operation.
- b. The materials testing laboratory performing the tests must be onsite for sampling and field testing and conform with ASTM C1077.
- c. Concrete shall be sampled and tested for quality control by the Contractor during the placement of the concrete as follows:

Requirement	Test	Method	Testing Frequency
Air Content	ASTM	C231/C231M	Perform all tests when test specimens are fabricated. One air content tests shall be performed during each 8-hour period of concrete production.
Slump	ASTM	C143/C143M	Perform all tests when test specimens are fabricated. One slump tests shall be performed on each separate concrete mixture produced during each 8-hour period of concrete production.
Temperature	ASTM	C1064/C1064M	Perform all tests when test specimens are fabricated
Strength	ASTM	C31/C31M C39/C39M	Perform all tests on at least one set of test specimens on each mixture placed during the day for each fifty cubic yards placed or portion thereof of that concrete mixture placed each day.

6.3.4.1 Strength Specimens

Perform on at least one set of test specimens, for Concrete Compressive Strength as appropriate, on each different concrete mixture placed during the day for each 50 cubic yards or portion thereof of that concrete mixture placed each day.

- a. A set of test specimens for concrete consists of four specimens, one to be tested at 7 days, two at 28 days, and one held in reserve. The 28-day strength shall be the average strength obtained from testing two cylinders.
- b. Immediately report 7-day and 28-day results to the District.

6.3.4.2 Temperature, Slump, and Air Content

Record the temperature, slump, and air content for each set of test cylinders made. Submit temperature reading, slump, and air content results to the District.

6.3.5 Repair, Rehabilitation and Removal

Before the District accepts the structure and final payment is made, inspect the structure for cracks, damage and substandard concrete placements that may adversely affect the service life of the structure. Submit a report documenting these defects, which includes recommendations for repair, removal and/or remediation to the District for approval before any corrective work is accomplished.

6.3.5.1 Crack Repair

Prior to final acceptance, document and repair all cracks in excess of 0.02 inches wide. Submit the proposed method and materials to repair the cracks to the District for approval. Address the amount of movement expected in the crack due to temperature changes and loading.

6.3.5.2 Repair of Weak Surfaces

Weak surfaces are defined as mortar-rich, rain-damaged, uncured, or containing exposed voids or deleterious materials. Diamond grind concrete surfaces with weak surfaces less than 1/4 inch thick to remove the weak surface. Remove and replace surfaces containing weak surfaces greater than 1/4 inch thick, or mitigate in a manner acceptable to the District.

6.4 MEASUREMENT AND PAYMENT

6.4.1 Measurement

Cast-in-Place Concrete will not be measured for payment.

6.4.2 Payment

Supply, preparation, and placement of cast-in-place concrete will be paid at the bid schedule bid item "RECONSTRUCTION FLOOD WALL". See Technical Provisions, Section 8.5.

7. CLEANUP

7.1 General

Throughout all phases of construction, including suspension of work, and until final acceptance of the project, the Contractor shall keep the premises occupied in a clean and orderly condition, disposing of refuse in a manner satisfactory to the District and in accordance with existing governmental regulations.

7.2 Detailed Requirements

Roadways will be cleared of excessive debris and waste at the end of each day to ensure safe conditions for traffic through the public right of way. All attempts will be made to keep the roadways clear throughout the project to limit excessive buildup of debris and litter.

All gutters and roadside ditches shall be clean and free from any obstructions. Any deviation from this practice shall have the prior approval of the District. Any areas of the existing levee road that are disturbed shall be restored to at least the preexisting condition at no additional cost to the District.

7.3 Final Cleanup of Premises and Work Site

As a final condition of acceptance of the work, the Contractor shall carefully cleanup the work and the premises, remove all temporary structures, remove all surplus materials, debris, and rubbish of all kinds from the grounds, which he has occupied, and leave them in a neat condition. The entire project shall be left in a condition that will present a pleasing appearance as viewed in general and in a manner satisfactory to the District.

7.4 Completion

The Contractor, upon completion of all work, shall restore the areas surrounding the work sites and project sites to a condition as good as or better than existed prior to the commencement of work.

7.5 Payment

Full compensation for all costs incurred and the work covered in this Section shall be considered as included in the unit prices according to the Bid Items as set forth in the Contractor's bid, and no additional or separate compensation will be allowed therefore.

8. MEASUREMENT AND PAYMENT:

8.1 Mobilization/ and Demobilization

Full compensation for mobilization and demobilization costs incurred shall be included in the unit prices according to the Bid Items set forth in the Contractor's bid. Work in this section shall include obtaining all bonds, permits, and licenses and full compensation for furnishing labor, materials, tools, equipment, cleanup, and incidentals, and for doing all work involved in mobilization and demobilization as specified herein. Mobilization and demobilization will be paid at the contract lump-sum price for the flood wall demolition work and for the flood wall panel reconstruction separately. Payment shall constitute full compensation for all the work involved in mobilization to and demobilization from the project site.

8.2 Flood Wall Demolition and Waste Disposal

Payment will be made for removal of a panel from the existing floodwall at the contract lump-sum price for item "DEMOLISH EXISTING FLOOD WALL PANEL". Payment shall constitute full compensation for furnishing all supplies, labor, equipment, water, and material for performing the work as described in the Contract Documents, including excavation and stockpiling of excavated material to permit saw cutting, saw cutting and removal of the existing flood wall, protection of the remaining structure during construction operations, and removal of demolition waste disposal off site in a legal fashion.

8.3 Provide All Reinforcement and Dowels

Payment will be made for providing reinforcement bars and dowels at the contract lump-sum price for item "PROVIDE All REINFORCEMENT AND DOWELS". Payment shall constitute full compensation for furnishing all materials cut, bent, and ready for installation.

8.4 Drill and Install Dowels and Vertical Reinforcement

Payment will be made for drilling and installing dowels and vertical reinforcement at the contract lump-sum price for item "INSTALL DOWELS AND VERTICAL REBAR". Payment shall constitute full compensation for furnishing all supplies, labor, equipment, epoxy adhesive, and other materials for performing the work as described in the Contract Documents, including cleanup and preparation of concrete surfaces, concrete coring, installation of adhesive, and setting of dowels and reinforcement bars.

8.5 Wall Panel Reconstruction

Payment will be made for flood wall panel reconstruction at the contract lump-sum price for item "RECONSTRUCTION FLOOD WALL". Payment shall constitute full compensation for furnishing all supplies, labor, equipment, and materials for performing the work as described in the Contract Documents, including cleanup and preparation of concrete surfaces, installing and removing formwork, installing reinforcement, installing joint fillers, providing and placing ready-mix concrete, curing and finishing, and caulking joints.

8.6 Laboratory Services

Payment will be made for materials laboratory testing services to sample and test ready-mix concrete at the point of delivery at the contract lump-sum price for item "PROVIDE LABORATORY SERVICES".

Payment shall constitute full compensation for site sampling, site testing as required, curing and testing of sample cylinders, and reporting.

**APPENDIX A
LABOR COMPLIANCE PROGRAM**

**APPENDIX A
LABOR COMPLIANCE PROGRAM**

The Federal and State labor law requirements applicable to the contract include but are not limited to the following items:

1. The Contractor’s duty to pay prevailing wages under Labor Code section 1770 et seq., should the project exceed the exemption amounts.
2. The Contractor’s duty to employ registered apprentices on the public works project under Labor Code section 1777.5.
3. The penalties for failure to pay prevailing wages (for non-exempt projects) and employ apprentices including forfeitures and debarment under Labor Code sections 1775 and 1777.7.
4. The requirement to keep and submit copies upon request of certified payroll records under Labor Code section 1776, and penalties for failure to do so under Labor Code section 1776(g).
5. The prohibition against employment discrimination under Labor Code section 1777.6, the Government Code, and Title VII of the Civil Rights Act of 1964.
6. The prohibition against accepting or extracting kickback from employee wages under Labor Code section 1778.
7. The prohibition against accepting fees for registering any person for public work under Labor Code section 1779, or for filling work orders on public works under Labor Code section 1780.
8. The requirement to list all subcontractors under Public Contracts Code section 4104.
9. The requirement to be properly licensed and to require all subcontractors to be properly licensed and the penalty for employing workers while unlicensed under Labor Code section 1021 and under the California Contractors License Law, found at Business and Professions Code section 7000 et seq.
10. The prohibition against unfair competition under Business and Professions Code section 17200–17208.
11. The requirement that the Contractor be properly insured for Workers’ Compensation under Labor Code section 1861.
12. The requirement that the Contractor abide by the Occupational, Safety and Health laws and regulations that apply to the particular construction project.
13. The Federal prohibition against hiring undocumented workers, and the requirement to secure proof of eligibility/citizenship from all workers.
14. The requirement to provide itemized wage statements to employees under Labor Code section 226.

Certification:

I acknowledge that I have been informed and am aware of the foregoing requirements and that I am authorized to make this certification on behalf of _____.

Name of Subcontractor

Date

Name of Person Signing and Company

**APPENDIX B
PROJECT EXHIBITS**

AMERICAN RIVER FLOOD CONTROL DISTRICT ARCADE CREEK EROSION REMEDIATION

FLOOD WALL PANEL REMOVAL AND REPLACEMENT ARCADE CREEK NORTH LEVEE



LIST OF DRAWINGS:		
SHEET	NUMBER	TITLE
1	G-001	TITLE SHEET AND LIST OF DRAWINGS
2	C-001	FLOOD WALL PANEL REMOVAL AND REPLACEMENT DETAILS

LOCATION MAP
SCALE: NTS

NOT FOR CONSTRUCTION

PLOTTED BY: BARNES, JOSEPH - January 25, 2022 - 3:44:42 PM
 DRAWING: \\NA.AECOM\NET\COM\JFB\AMER\SACRAMENTO\SSCR2\SECURE_DCS\PROJECTS6\SAFCA-NS\12_DESIGN\ARFCD
 FLOOD WALL MBK-G-001.DWG

REV.	DATE	BY	CHK.	APPR.	DESCRIPTION
A	1/25/2022	JB			FOR REVIEW AND PERMITTING

DESIGNED BY: J. Barnes
 DRAWN BY: J. Barnes
 CHECKED BY: K. Myers
 S. Aviles
 IN CHARGE: K. Myers
 DATE:

AECOM

2020 L Street, Suite 400
 Sacramento, CA 95811
 TEL: (916) 414-5800
 FAX: (916) 414-5850

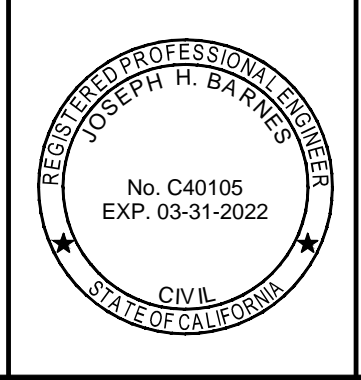

AMERICAN RIVER FLOOD CONTROL DISTRICT
 ARCADE CREEK EROSION REMEDIATION
 FLOOD WALL PANEL REMOVAL AND REPLACEMENT
 NORTH LEVEE

PLANS
**TITLE SHEET
 AND LOCATION MAP**

VERIFY SCALES
 BAR IS ONE INCH ON ORIGINAL
 DRAWING. ADJUST SCALE FOR
 REDUCED PLOTS

DRAWING NO. SHEET
G-001 1

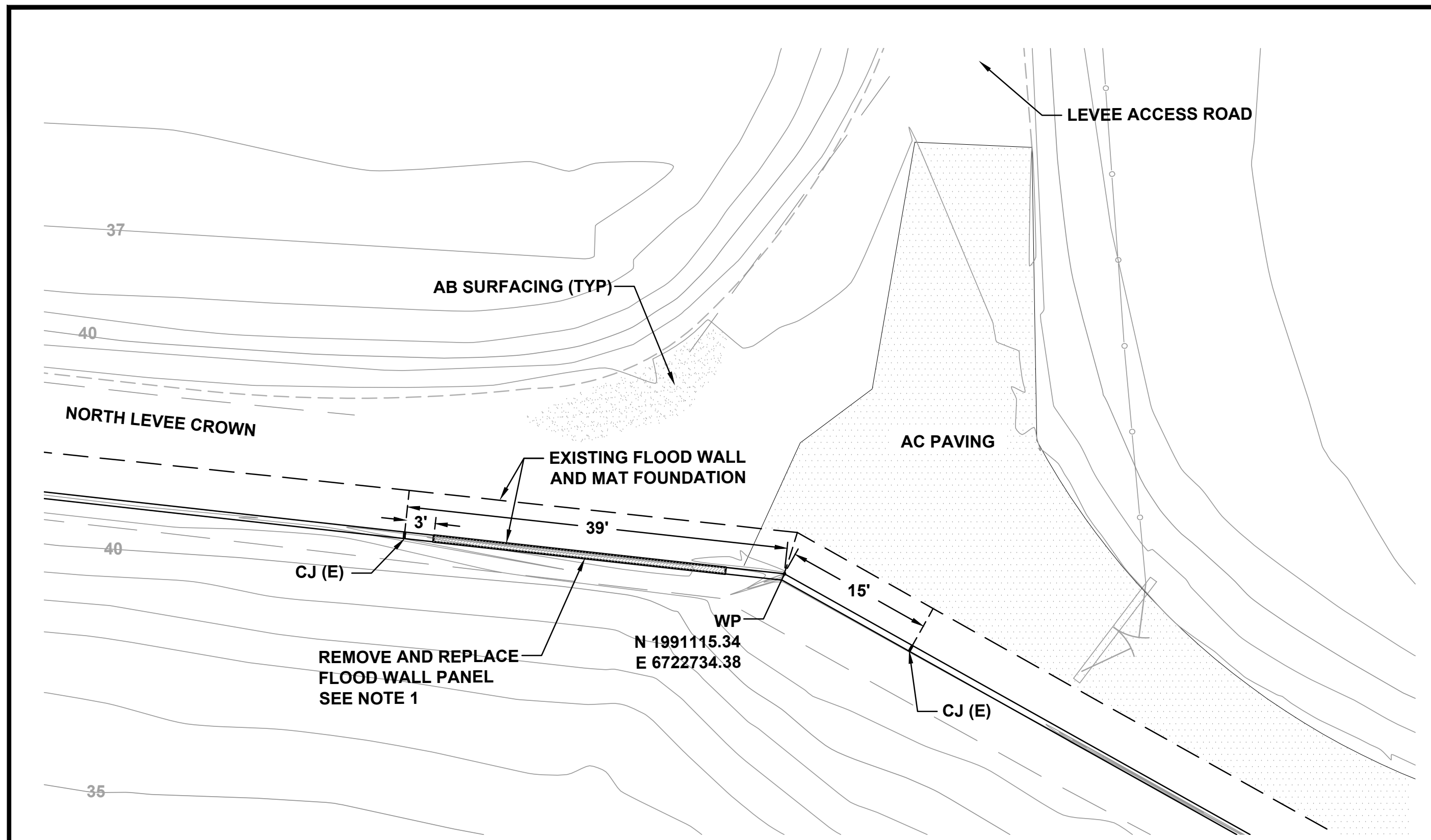

PLAN - FLOOD WALL PANEL REMOVAL
SCALE: 1" = 10'

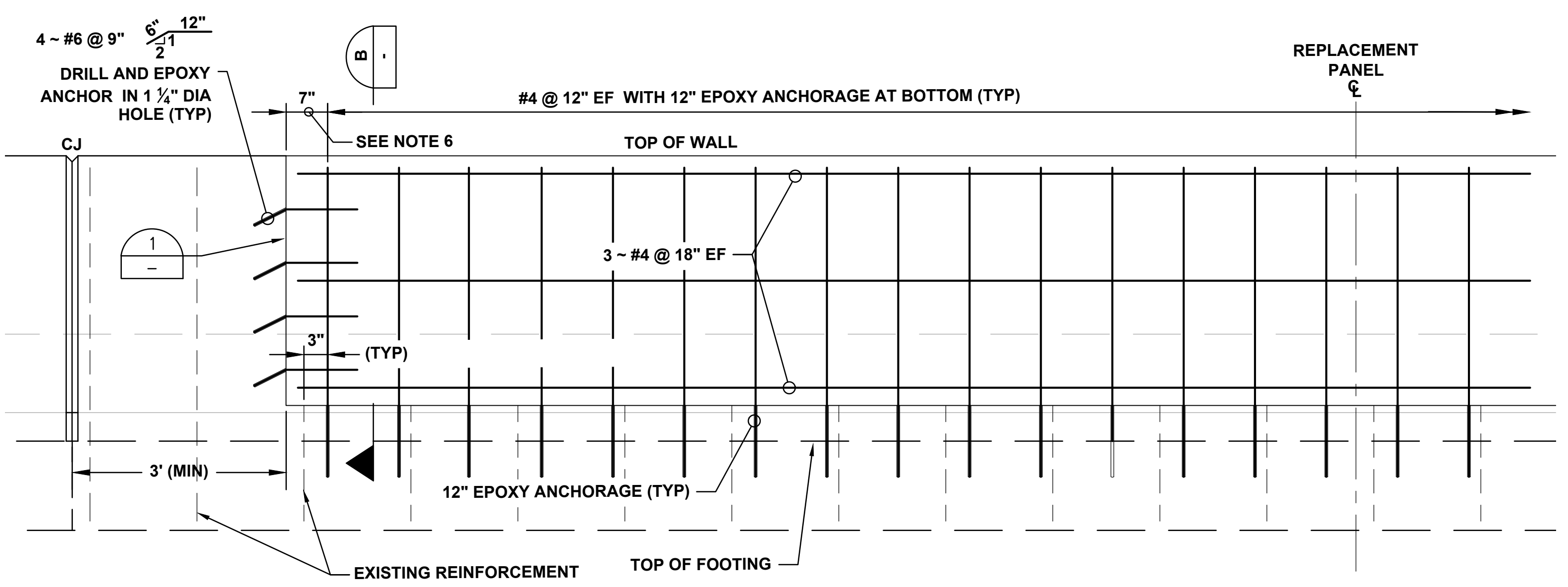

ELEVATION - FLOOD WALL PANEL RECONSTRUCTION
SCALE: NTS

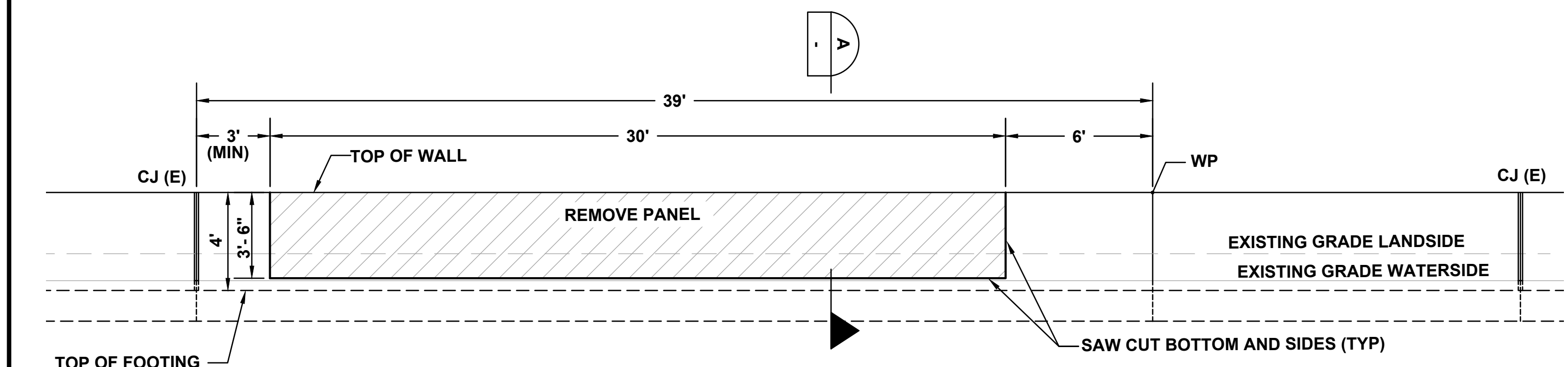

ELEVATION - FLOOD WALL PANEL REMOVAL
SCALE: NTS

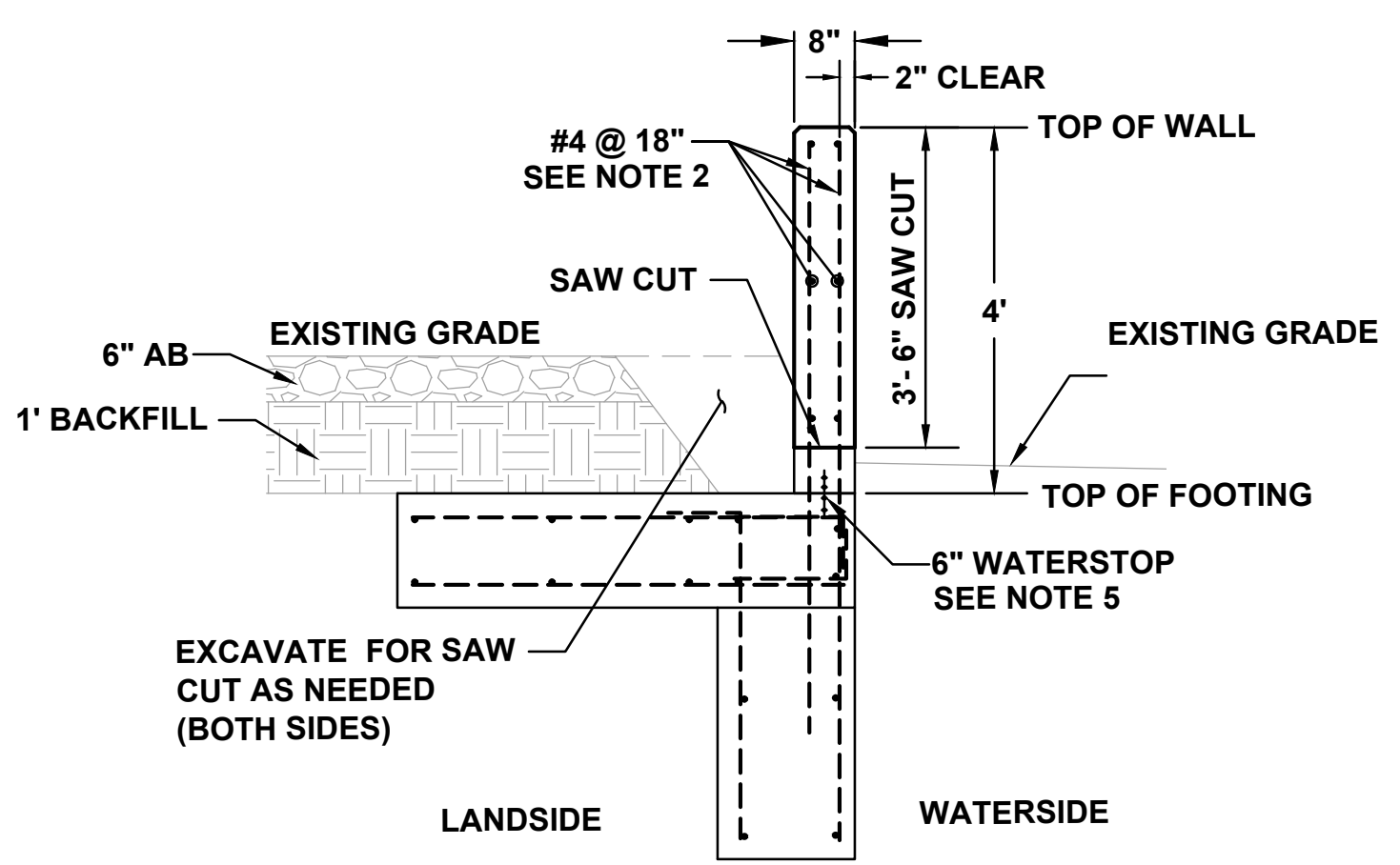

EXISTING FLOOD WALL SECTION
NTS

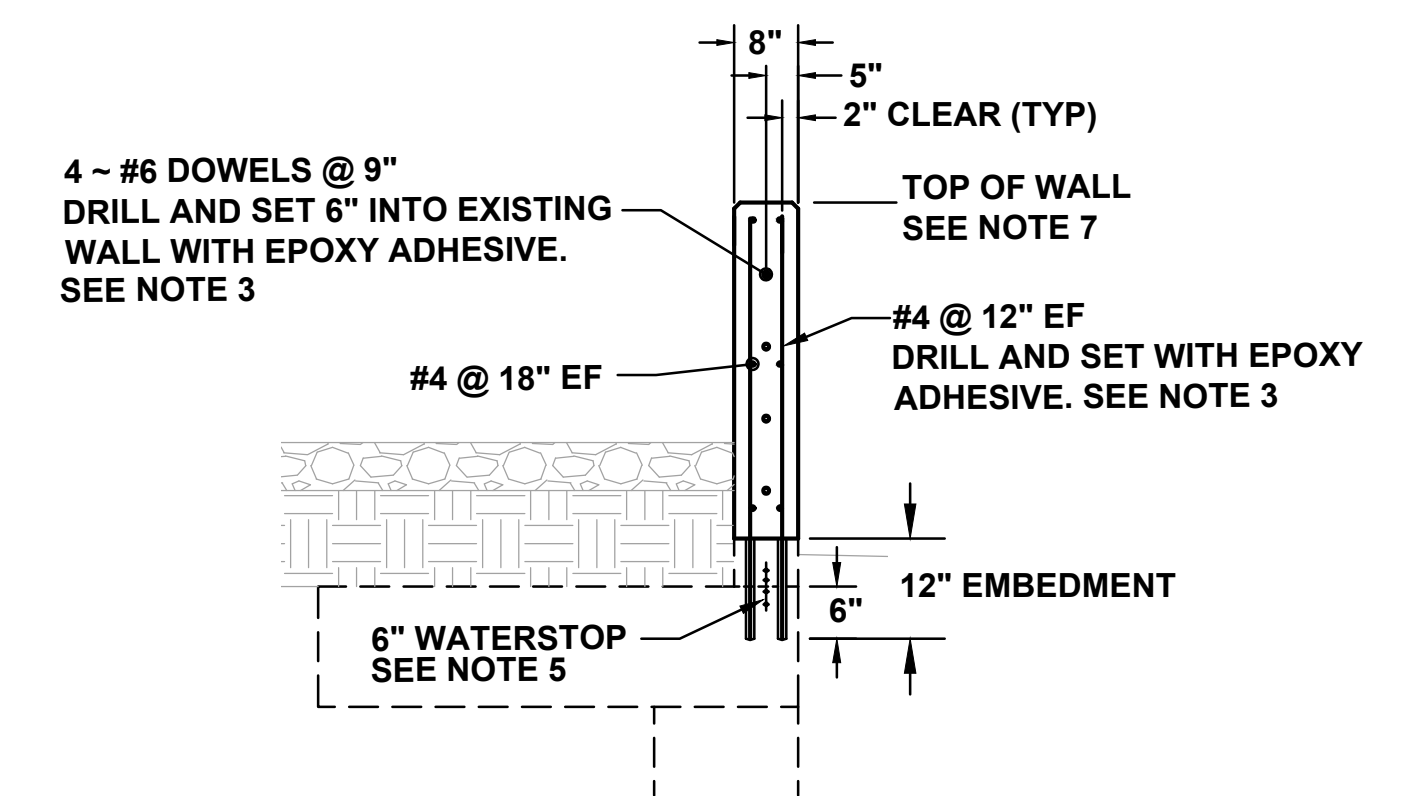

FLOOD WALL RECONSTRUCTION
NTS

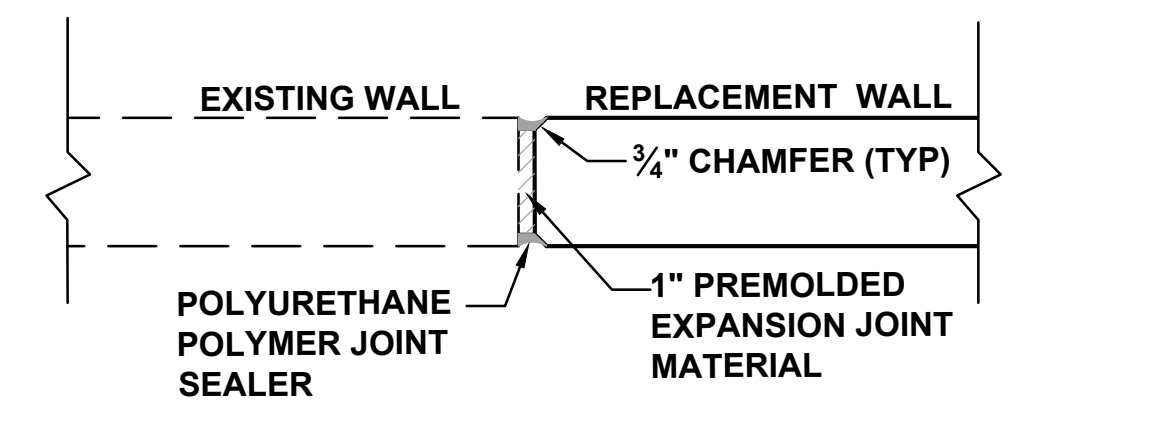

DETAIL - CONSTRUCTION JOINT
NTS

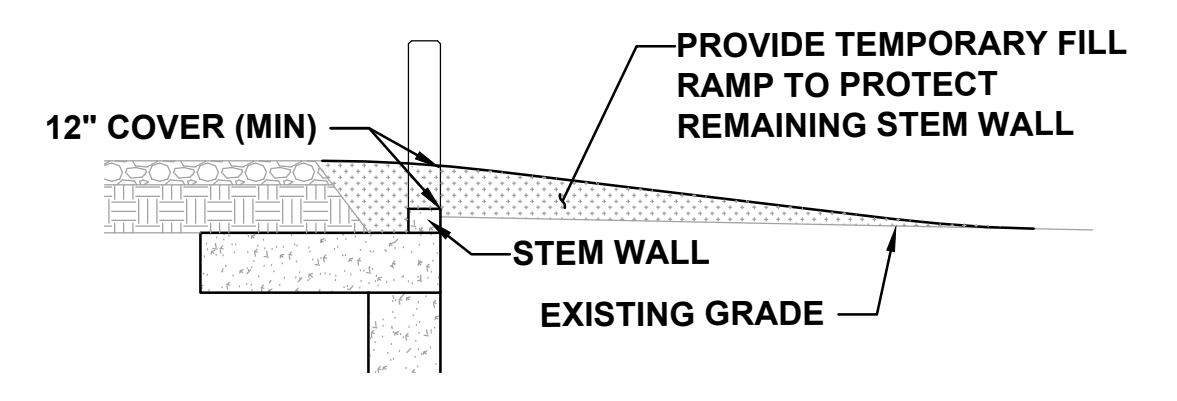

DETAIL - TEMPORARY RAMP
NTS

- NOTES:**
- WITH OWNER APPROVAL, PANEL REMOVAL LOCATION AND LENGTH MAY BE VARIED TO ACCOMMODATE TURNING RADIUS OF ACTUAL ROCK HAUL TRUCKS BEING USED.
 - TYPICAL EXISTING WALL DIMENSIONS AND REINFORCEMENT BASED ON AS-BUILT PLANS, DRAWING S-3, ARCADE CREEK LEVEE IMPROVEMENTS, UNIT 1B, DATED 5-15-1997.
 - EPOXY ADHESIVE FOR ANCHORING REINFORCING BARS AS SHOWN ON THE PLANS SHALL BE SIMPSON SET-HP OR ACCEPTABLE EQUAL.
 - DRILLING, CLEANING, AND INSTALLATION OF REINFORCING BARS IN ANCHORAGE HOLES SHALL BE IN ACCORDANCE WITH EPOXY ADHESIVE MANUFACTURER RECOMMENDATIONS.
 - PROTECT EXISTING WATERSTOP IN PLACE.
 - DIMENSION MAY VARY DEPENDING ON ACTUAL LOCATION OF EXISTING REINFORCEMENT.
 - SLOPE TOP OF REPLACEMENT WALL TO MATCH EXISTING TOP OF WALL ELEVATIONS AT BOTH ENDS.
 - SEE DETAIL 2 FOR TEMPORARY FILL TO PROTECT STEM WALL FROM TRUCK TRAFFIC.

- SPECIFICATIONS:**
- CONCRETE**
- READY MIXED PER ASTM C-94. MINIMUM 28-DAY COMPRESSIVE STRENGTH OF 4,000 PSI. MAXIMUM SLUMP 4" AT TIME OF PLACEMENT.
- REINFORCEMENT**
- ASTM A-615 DEFORMED BARS, GRADE 60.
 - LAP HORIZONTAL BARS 30 INCHES IN CONCRETE WHERE NECESSARY AND STAGER SPLICES. SPLICING OF VERTICAL BARS NOT PERMITTED.
- ABBREVIATIONS:**
- AB AGGREGATE BASE
AC ASPHALT CONCRETE
CJ CONSTRUCTION JOINT
E EXISTING
EF EACH FACE
WP WORK POINT

NOT FOR CONSTRUCTION

PLOTTED BY: BARNES, JOSEPH - January 25, 2022 - 3:44:42 PM
 DRAWING: \\NA.AECOM\NET\WORK\AMER\SACRAMENTO\SSCR2\SECURE_DCS\PROJECTS\6\SAFCA-NE\12_DESIGN\ARFCD\FLOOD WALL MBK\C-001.DWG

DESIGNED BY:	J. Barnes				
DRAWN BY:	J. Barnes				
CHECKED BY:	K. Myers S. Aviles				
IN CHARGE:	K. Myers				
DATE:					
REV.	DATE	BY	CHK.	APPR.	DESCRIPTION
A	1/25/2022	JB			FOR REVIEW AND PERMITTING

DESIGNED BY: J. Barnes
 DRAWN BY: J. Barnes
 CHECKED BY: K. Myers
 S. Aviles
 IN CHARGE: K. Myers
 DATE:

AECOM

2020 L Street, Suite 400
Sacramento, CA 95811
TEL: (916) 414-5800
FAX: (916) 414-5850

REGISTERED PROFESSIONAL ENGINEER
JOSEPH H. BARNES
No. C40105
EXP. 03-31-2022
CIVIL
STATE OF CALIFORNIA

AMERICAN RIVER FLOOD CONTROL DISTRICT
ARCADE CREEK EROSION REMEDIATION

AMERICAN RIVER FLOOD CONTROL DISTRICT

FLOOD WALL PANEL REMOVAL AND REPLACEMENT
NORTH LEVEE

PLANS

FLOOD WALL PANEL REMOVAL AND REPLACEMENT DETAILS

DRAWING NO. **C-001** SHEET **2**

VERIFY SCALES
BAR IS ONE INCH ON ORIGINAL
DRAWING. ADJUST SCALE FOR
REDUCED PLOTS

0" 1"

DRAWING NO. **C-001** SHEET **2**

ORDINANCE NO. 2020-0009

Adopted by the Sacramento City Council

February 25, 2020

An Ordinance Adding Chapter 8.140 to the Sacramento City Code, Relating to Protection of Critical Infrastructure and Wildfire Risk Areas

BE IT ENACTED BY THE COUNCIL OF THE CITY OF SACRAMENTO:

SECTION 1.

Chapter 8.140 is hereby added to the Sacramento City Code to read as follows:

Chapter 8.140 PROTECTION OF CRITICAL INFRASTRUCTURE AND WILDFIRE RISK AREAS

8.140.010 Findings and purpose.

The City Council finds as follows: (1) a principal threat to the public health, safety, and welfare is the potential destruction of, damage to, or interference with, infrastructure that is critical to the provision of public services such as law enforcement, fire prevention, transportation, and utilities including communication, water, and waste disposal; (2) destruction of, damage to, or interference with, critical infrastructure is caused by fire, contamination, restricting access, or other causes; and (3) destruction of, damage to, or interference with, critical infrastructure is often caused by persons whose activities are not permitted or authorized in, on, or near critical infrastructure.

The purpose of this chapter to mitigate the threat of fire and other potential causes of destruction and damage to and interference with, critical infrastructure, in order to protect the health, safety, and welfare of the public, by authorizing the removal of persons and their personal property in, on, or near critical infrastructure.

8.140.020 Definitions.

When used in this chapter, the following words and phrases have the following meanings:

“Camp” has the same meaning as in section 12.52.020.

“Camp facilities” has the same meaning as in section 12.52.020.

“Camp paraphernalia” has the same meaning as in section 12.52.020.

“Critical infrastructure” means each of the following:

1. Levees; or

2. Real property or a facility, whether privately or publicly owned, as approved by resolution of the city council, that the city manager designates as being so vital and integral to the operation or functioning of the city that its damage, incapacity, disruption, or destruction would have a debilitating impact on the public health, safety, or welfare.

Critical infrastructure may include, but is not limited to, government buildings, such as fire stations, police stations, jails, or courthouses; hospitals; structures, such as antennas, bridges, roads, train tracks, drainage systems, or levees; or systems, such as computer networks, public utilities, electrical wires, natural gas pipes, telecommunication centers, or water sources.

“Debris” has the same meaning as in section 13.10.010.

“Facility” means a building, structure, equipment, system, or asset.

“Fire prevention official” means the fire chief, a deputy fire chief, the fire marshal, or a fire prevention officer.

“Garbage” has the same meaning as in section 13.10.010.

“Hazardous waste” has the same meaning as in California Public Resources Code section 40141.

“Hollow sidewalk” means a sidewalk that has been determined to be a hollow sidewalk in “Raised Streets & Hollow Sidewalks” survey report of July 20, 2009, prepared by Page & Turnbull, Inc. for the City of Sacramento.

“Infectious waste” has the same meaning as in California Code of Regulations, title 14, section 17225.36.

“Solid waste” has the same meaning as in section 13.10.010.

“Wildfire risk area” has the same meaning as in California Code of Regulations, title 24, part 9, section 202.

8.140.030 Prohibited activities.

A. It is unlawful and a public nuisance for any person to camp, occupy camp facilities, or use camp paraphernalia at the following locations:

1. Critical infrastructure;
2. Within 25 feet of critical infrastructure;
3. Within 25 feet of a vehicular or pedestrian entrance or exit of critical infrastructure;
4. On those portions of a right-of-way that are required by local, state, or federal law to be free of obstruction to first responders, including but not limited to members of law-enforcement, fire-prevention, or emergency-medical-services agencies;
5. Within a hollow sidewalk; or
6. Wildfire risk area.

B. It is unlawful and a public nuisance for any person to store personal property, including camp facilities and camp paraphernalia, in the following locations without the written consent of the owner, except as otherwise provided by resolution of the city council:

1. Critical infrastructure;
2. Within 25 feet of critical infrastructure;
3. Within 25 feet of a vehicular or pedestrian entrance or exit of critical infrastructure;
4. On those portions of a right-of-way that are required by local, state, or federal law to be free of obstruction to first responders, including but not limited to members of law-enforcement, fire-prevention, or emergency-medical-services agencies;
5. Within a hollow sidewalk; or

6. Wildfire risk area.

C. It is not intended by this section to prohibit overnight camping on private residential property by friends or family of the property owner, so long as the owner consents and the overnight camping is limited to not more than one consecutive night.

D. Nothing in this chapter is intended to prohibit or make unlawful the activities of an owner of private property or other lawful user of private property that are normally associated with and incidental to the lawful and authorized use of private property for residential or other purposes; and nothing is intended to prohibit or make unlawful the activities of a property owner or other lawful user if such activities are expressly authorized by the Planning and Development Code or other laws, ordinances, and regulations.

8.140.040 Summary abatement.

A. Any violation of section 8.140.030 may be abated by the city upon 24 hours of prior notice; but a violation of section 8.140.030 may be abated immediately by the city without prior notice, if the violation poses an imminent threat to public health or safety.

B. Abatement pursuant to subsection A may include, but is not limited to, removal of camp facilities, camp paraphernalia, personal property, garbage, hazardous waste, infectious waste, junk, or debris; and securing the perimeter of the property with fencing, gates, or barricades to prevent further occurrences of the nuisance activity.

C. Regardless of the city's authority to conduct abatement pursuant to this section, every owner, occupant, or lessee of real property, and every holder of any interest in real property, is required to maintain the property in compliance with local, state, and federal law; and is liable for violations thereof.

D. The cost of abatement, including all administrative costs of any action taken hereunder, may be assessed against the subject premises as a lien, made a personal obligation of the owner, or both, in accordance with procedures in article VIII of chapter 8.04.

8.140.050 Interference with summary abatement.

No person shall willfully prevent, delay, resist, obstruct, or otherwise interfere with a city official, employee, contractor, or volunteer in their execution of an abatement

pursuant to this chapter.

8.140.060 Violation—Penalty.

A. In addition to any other remedy allowed by law, any person who violates a provision of this chapter is subject to criminal sanctions, civil actions, and administrative penalties pursuant to chapter 1.28.

B. Violations of this chapter are hereby declared to be a public nuisance.

C. Any person who violates a provision of this chapter is liable for civil penalties of not less than \$250 or more than \$25,000 for each day the violation continues.

D. All remedies prescribed under this chapter are cumulative and the election of one or more remedies does not bar the city from the pursuit of any other remedy to enforce this chapter.

Adopted by the City of Sacramento City Council on February 25, 2020, by the following vote:

Ayes: Members Ashby, Carr, Guerra, Hansen, Harris, Jennings, Schenirer, Warren and Mayor Steinberg

Noes: None

Abstain: None

Absent: None

Attest:

/s/
Mindy Cuppy, City Clerk

The presence of an electronic signature certifies that the foregoing is a true and correct copy as approved by the Sacramento City Council.

Passed for Publication: Not applicable
Published: To be published in its entirety
Effective: March 26, 2020

General Manager's Meeting Summary May 2022

5/6: CalTrans AR Bridge Project Coordination meeting. I attended this meeting with CalTrans staff and representatives from Cal Expo and Regional Parks to hear updates on the status of the CalTrans American River Bridge Widening Project. The meeting focused primarily on the bike trail detour along the Cal Expo levee and through the Tribute Road undercrossing.

5/10: CalTrans AR Bridge Project Coordination meeting. I attended this meeting with CalTrans staff and representatives from Regional Parks to hear updates on the status of the CalTrans American River Bridge Widening Project. County Parks requested the meeting to discuss the Bike Trail access on the North Levee.

5/12: American River Parkway Fire Safe Council meeting. I met with stakeholders along the American River Parkway to discuss the fire danger within the Parkway. The group discussed key actions to protect the Bushy Lake area from fires while being sensitive to threatened species and habitat.

5/13: American River Flood Control District Board of Trustees meeting. The Board met in regular session. The agenda items included a closed session item regarding pending litigation, solicitation for rock rip-rap bids, the FY 22-23 Budget and 5-year Plan, a Fixed Asset and Capitalization Policy, a resolution to Levy a Benefit Assessment, and selection of a company to perform demographic and By-District elections mapping.